

Weishaupt Monarch oil burners Sizes 5 to 11

1/2002 GB

–weishaupt–



Description, Types of regulation, Model overview

– weishaupt –

Weishaupt Monarch oil burners are of the fully automatic pressure atomising type. Their design has been carefully considered down to the smallest detail and has been proved successful over and over again. They meet all the demands for safety, reliability and low cost servicing. Weishaupt oil burners are type tested (except for residual oil burners).

The burners are distinguished by a variety of interesting features:

- Larger range of application 15 - 440 kg/h (180 - 5420 kW)
- Automatic sequence of operations
- Stable fan characteristics - good combustion results
- Air damper closed on burner shutdown
- Quiet operation
- Complete pre-wired integral switchgear (except for RL and RMS burners, L10T three stage burner and burners to TRD)
- Hinged burner casing
- Combustion head can be withdrawn when the burner is hinged open (sizes 9 to 11)
- The design of the burner makes installation, adjustment and servicing easy

Construction

All the components are assembled in one unit. The motor drives the fan and the fuel pump. All the equipment used for the regulation of fuel and air is clearly arranged and easily accessible. The burners can be hinged to the left or right, which simplifies service work on the combustion head, diffuser, nozzles and ignition electrodes.

Application

The burners can be used on hot water boilers, steam boilers, air heaters and for certain heating processes. RL and RMS burners are preferably used where there is a continually changing heat demand.

Fuels

Distillate, medium and heavy oil to DIN 51 603 can be fired (other fuels on request).

Viscosity:

Types Monarch L and RL -

up to 6 mm²/s at 20°C

Type Monarch M -

up to 75 mm²/s at 50°C

Types Monarch MS and RMS -

up to 50 mm²/s at 100°C

Regulation

On L, M and MS type burners, the regulation of oil and air takes place as follows:

- two stage, nozzle head with two nozzles and a motor controlled, quickly opening air damper (with return flow nozzle assembly and oil pump with two solenoid valves for LN version).

- three stage, with three nozzles and a motor controlled, slowly opening air damper.

For RL and RMS burners, fuel and air are controlled in compound. The burner can, depending on the controller and servomotor, be either:

- sliding two stage (servomotor with 20 s running time)
- modulating (servomotor with 42 s running time)

With sliding two stage regulation, the partial and full load positions are fixed within the burner operating range. The burner slides to one position or the other, depending on the appliance demand, and there are no rapid changes of fuel throughput.

By fitting a suitable controller into the control panel, the burner can be altered to modulating operation. Modulating burners operate at any point within the capacity range, depending on the heat demand.

On sliding two stage burners and modulating burners, the slow capacity alteration ensures a particularly good matching to the demand of the heating appliance.

Flame supervision

The burner controller automatically sequences the operations and monitors the flame optically via the flame sensor. For burners without inbuilt switchgear the controller is supplied loose for mounting in the control panel, or built in at extra cost.

No interference with radio and television reception

Radio interference created during ignition is below the permitted limits specified by the relevant EMC standards and regulations.

Nozzle recirculation system on residual oil burners

During prepurge on residual oil burners, heated oil flows through the nozzle head and oil line system. This ensures that evenly heated oil is available for flame establishment.

Air/gas separator

Oil circulation tank

Patented air/gas separators or oil circulation tanks are always required and should always be offered.

When using an air/gas separator or oil circulation tank, the preheated oil supplied through the return line is mixed into the flow to the burner. This results in an energy saving as only partial heating of the fuel oil is required.

Operation of a two pipe system is possible when using residual oil and a single burner, providing the suction vacuum does not exceed 4.0 bar. If several burners are supplied by a ring main via an air/gas separator or oil circulation tank, it is necessary to fit manually operated linked ball valves with limit switch immediately after the air/gas separator or oil circulation tank. Air/gas separators and oil circulation tanks should be selected to suit the pump rating of the ring main and the burner size. When selecting the ring main pump stations, please ensure that the rating is one and a half times to twice that of the nozzle rating.

Air/gas separators and oil circulation tanks must be located close to the burner.

Quiet operation

Weishaupt burners operate quietly. All air handling burner parts have been aerodynamically designed, the fuel / air mixing noise is reduced to a minimum and rotors and fan wheels are dynamically balanced. For installations where special emphasis is placed on burners with low noise levels, sound absorbers which considerably reduce burner noise (see brochure "Sound absorbing shrouds for Weishaupt burners", print No. 13).

Combustion of heavy oil

The oil throughput of type MS and RMS heavy oil burners, referenced to the nominal capacity, must be no less than 100 kg/h. Furthermore the use of RMS type burners is recommended when combusting this fuel.

Note for MS and RMS burners

Heavy oil burners may only be used outside the Federal Republic of Germany. The data given in the capacity graphs are maximal values. The values that can actually be achieved depend on the combustion chamber and should be determined from measurements on the heating appliance concerned.

Permissible ambient conditions

In standard execution (materials, construction, protection), the burners are suitable for use indoors and as such should not be installed outside. Permissible ambient temperatures are between -10°C and +40°C. Plant installed in unheated areas is subject to particular measures in certain circumstances (please enquire).

Special executions

Numerous special variants, for example burners to ships' execution or for use on process plant are available on request.

Explanation of type designation

Sliding two stage or modulating regulation

RL 8/2 - ZM D

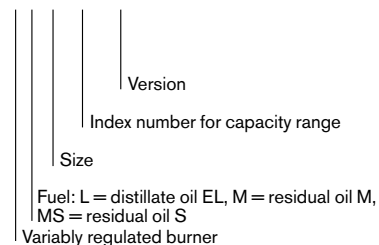

Two stage regulation (Z)

- Oil is released at start when solenoid valve 1 and the safety solenoid valve open.
- Full load is reached when solenoid valve 2 opens.
- The capacity is regulated by the opening and closing of solenoid valve 2.

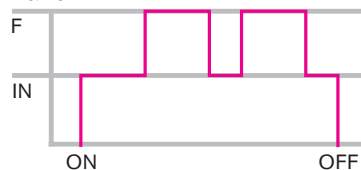

Three stage regulation (T)

distillate oil burners only

- Oil is released at start when solenoid valve 1 and the safety solenoid valve open.
- Full load is reached when solenoid valve 3 opens.
- The capacity is regulated by the opening and closing of solenoid valves 2 and 3.

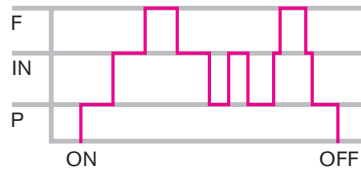

Sliding two stage and modulating regulation (ZM)

- When the nozzle needle and safety solenoid valve open, the right quantity of oil for the starting load is released (except RL5).
- A slow running servomotor adjusts the oil regulator up to full load.
- The burner capacity is regulated between partial and full load by the opening and closing of the oil regulator.
- Sliding two stage burner servomotors have a running time of 20 s and modulating burner servomotors have a running time of 42 s. For modulating operation a controller is required which is fitted into the control panel.



Sliding two stage

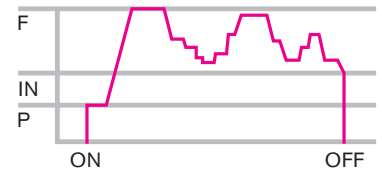

Modulating

F = full load, P = partial load, I = ignition load, IN = intermediate load

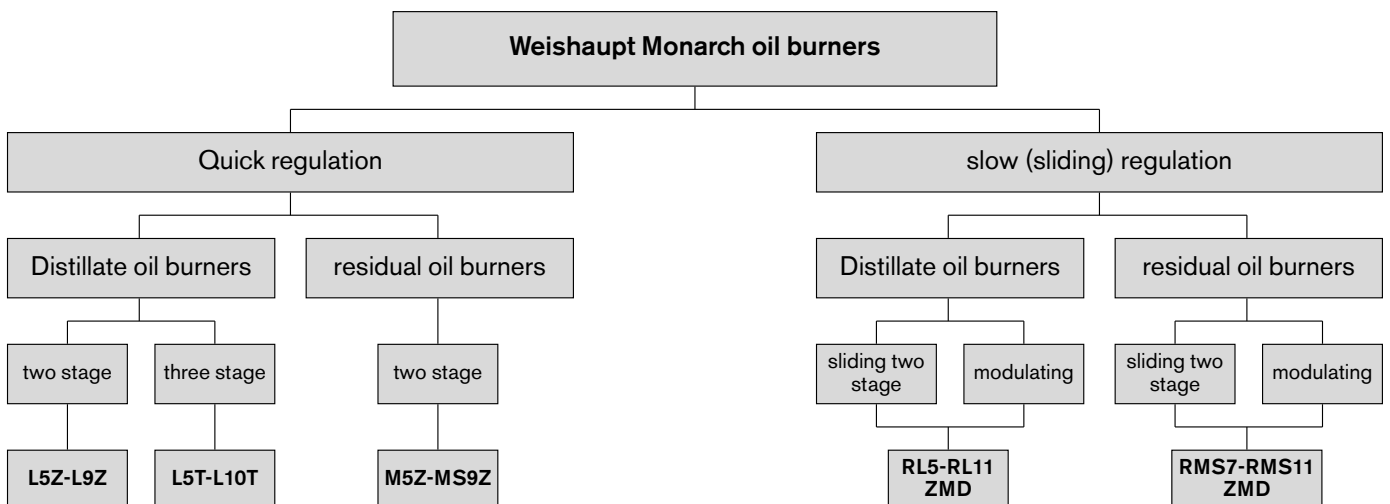

Scope of delivery

Distillate and residual oil burners

– weishaupt –

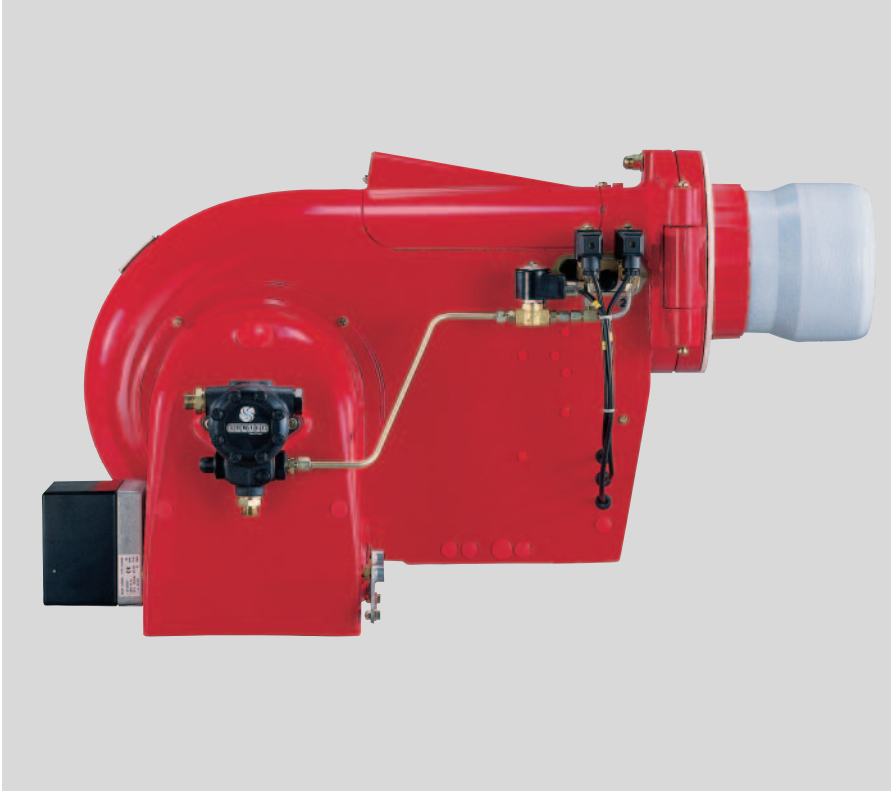

Monarch L distillate oil burner

Monarch L distillate oil burner

Two stage burner

- Burner housing
- Hinged flange with limit switch
- Flange gasket
- Sight glass
- Burner motor
- Fan wheel
- Pump
- Two solenoid valves and one safety valve
- Oil hoses
- Nozzle assembly with two nozzles
- Combustion housing
- Air regulation housing with air damper and servomotor
- Ignition unit
- Ignition cable
- Ignition electrodes
- Burner controller with flame sensor
With or without inbuilt switchgear
(see page 6 for inbuilt switching)

Three stage burner

The specification varies from that of the two stage burner as follows:

- Three solenoid valves and one safety valve
- Slow running servomotor
- Nozzle assembly with three nozzles

A separate control panel is required for size 10 burners.

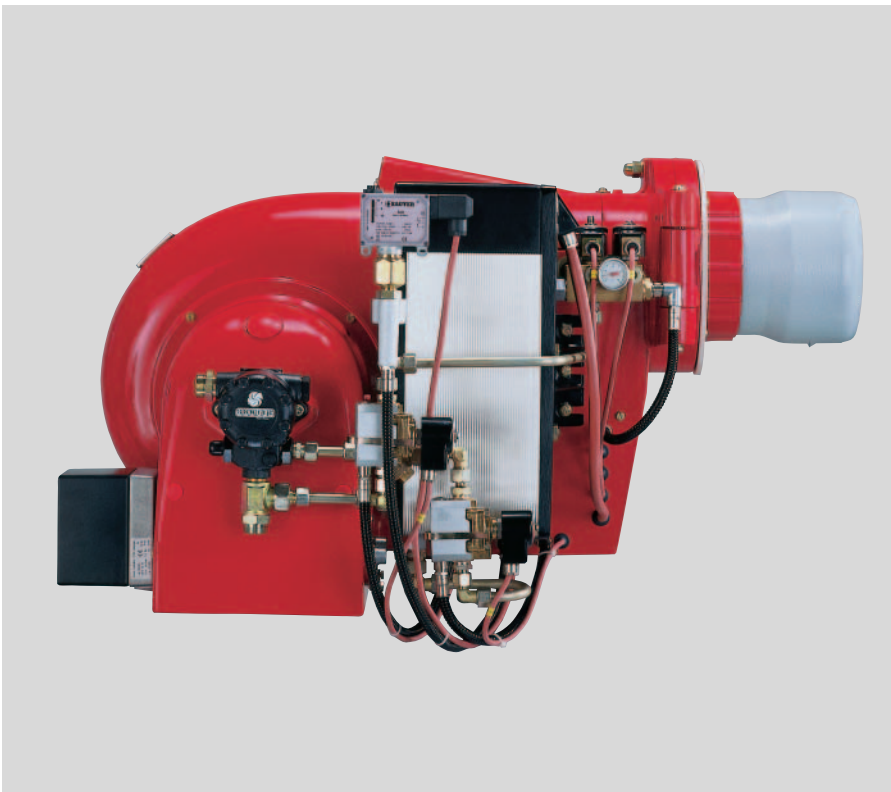

Monarch M/MS residual oil burner

Monarch M/MS residual oil burner

Residual burners also include:

- Oil preheater
- recirculation nozzle assembly
- Thermometer
- Heating cartridges (in the nozzle assembly, distributor piece, pressure switch and solenoid valves)
- ROB regulator
- Pressure switch
- Filter
- Stainless steel oil hoses

A separate control panel is required size MS9 Z burners.

– weishaupt –

Monarch RL distillate oil burner

Regulating, sliding two stage and modulating burners

The specification varies from that of the two stage burner as follows:

- Servomotor for oil / air regulation with regulating cam
- Oil regulator
- Nozzle assembly with spill back nozzle
- Two control solenoid valves
- Pressure switch
- Panel mounted burner controller. Inbuilt switchgear not available.

Modulating burners also require a panel mounted modulation controller (additional cost).

A separate control panel is required for burner sizes RL5 to RL11.

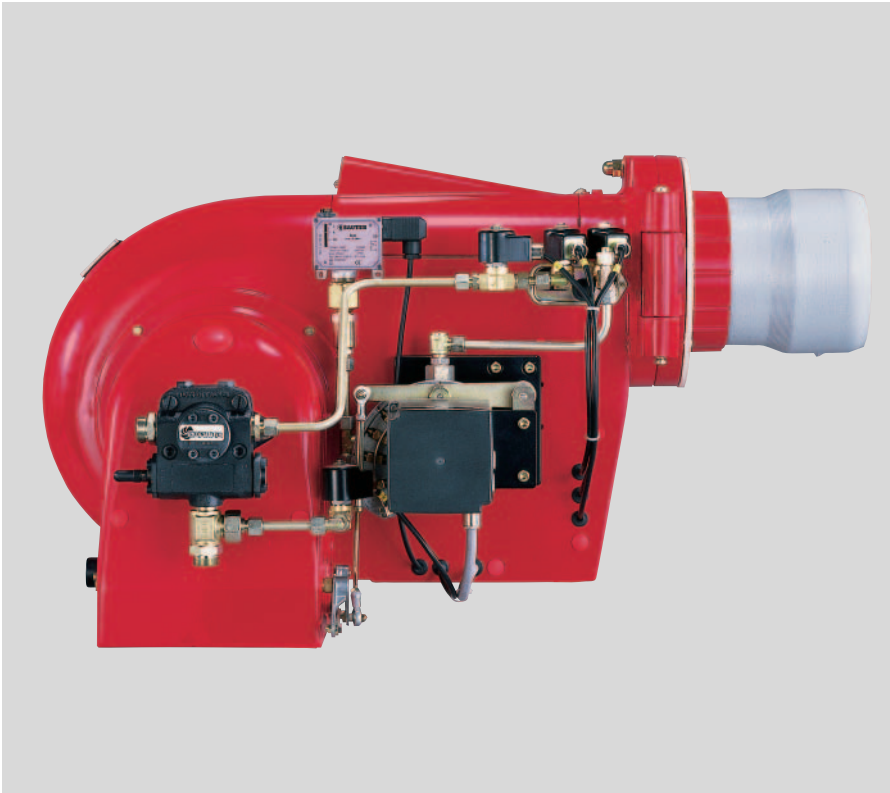

Monarch RL distillate oil burner

Monarch RMS residual oil burner

Residual burners also include:

- Oil preheater
- recirculation nozzle assembly
- Thermometer
- Heating cartridges (in the nozzle assembly, distributor piece, pressure switch and solenoid valves)
- ROB regulator
- Filter
- Stainless steel oil hoses

A separate control panel is required for burner sizes RMS7 to RMS11.

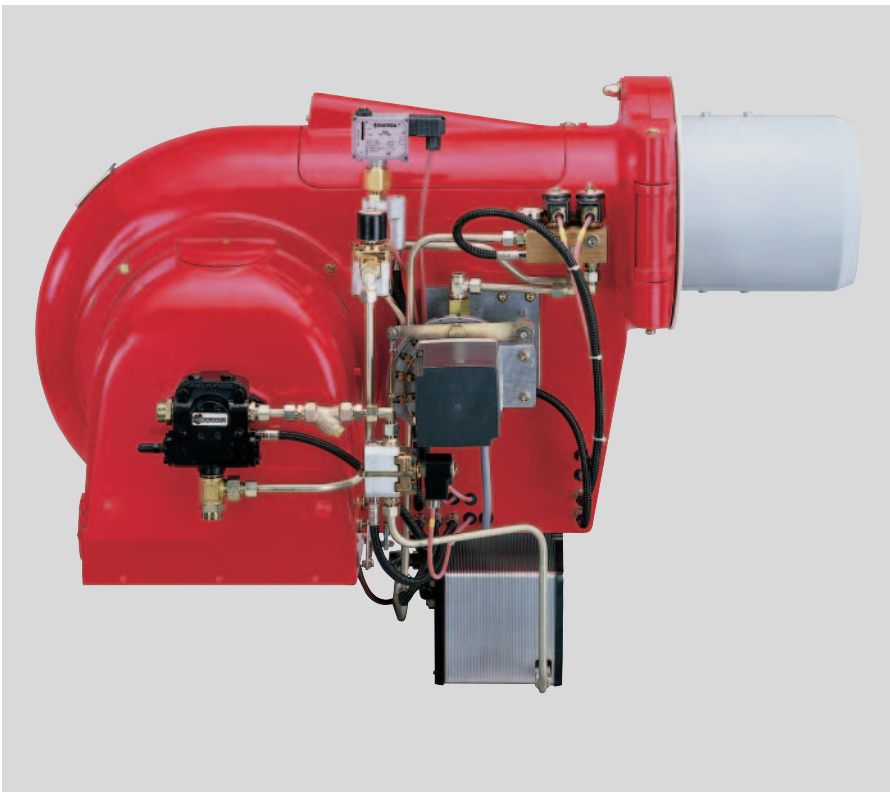

Monarch RMS residual oil burner

Components

– weishaupt –

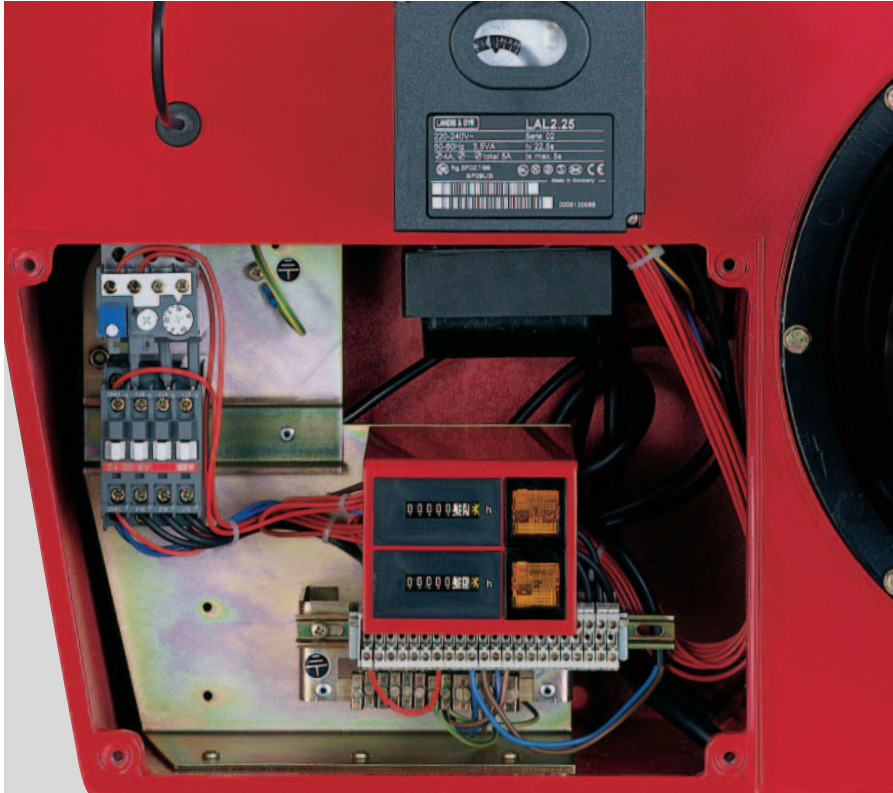

Complete integral switchgear on two and three stage Monarch L type burners

Burners with inbuilt switchgear have all the necessary elements for burner operation:

- 1 Stage 1 control switch with lamp
- 1 Stage 2 control switch with lamp
- 1 Contactor
- 1 Overload relay

Hours run meters can be fitted on request.

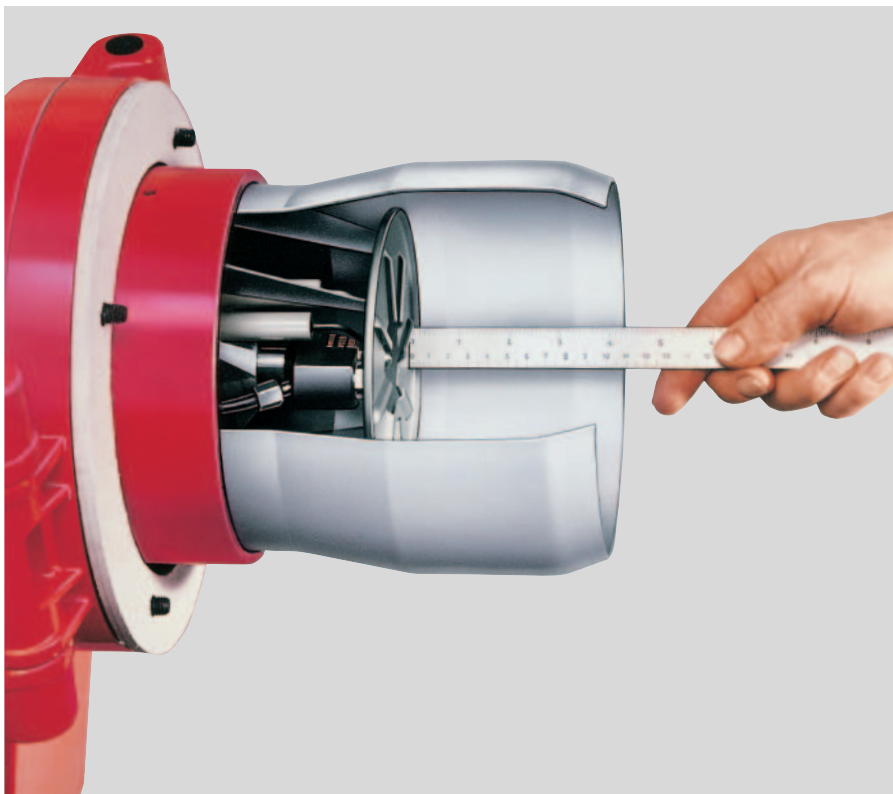

Adjustable and removable combustion heads

No one boiler is the same as another and yet one burner should perform economically on all boilers. The position of the combustion head and diffuser relative to each other can be altered. The burners are thus suited to the combustion chamber conditions.

There is a further advantage for burner sizes 9 to 11. With the burner hinged open, the combustion head and combustion head support can be removed through the hinged flange.

– weishaupt –

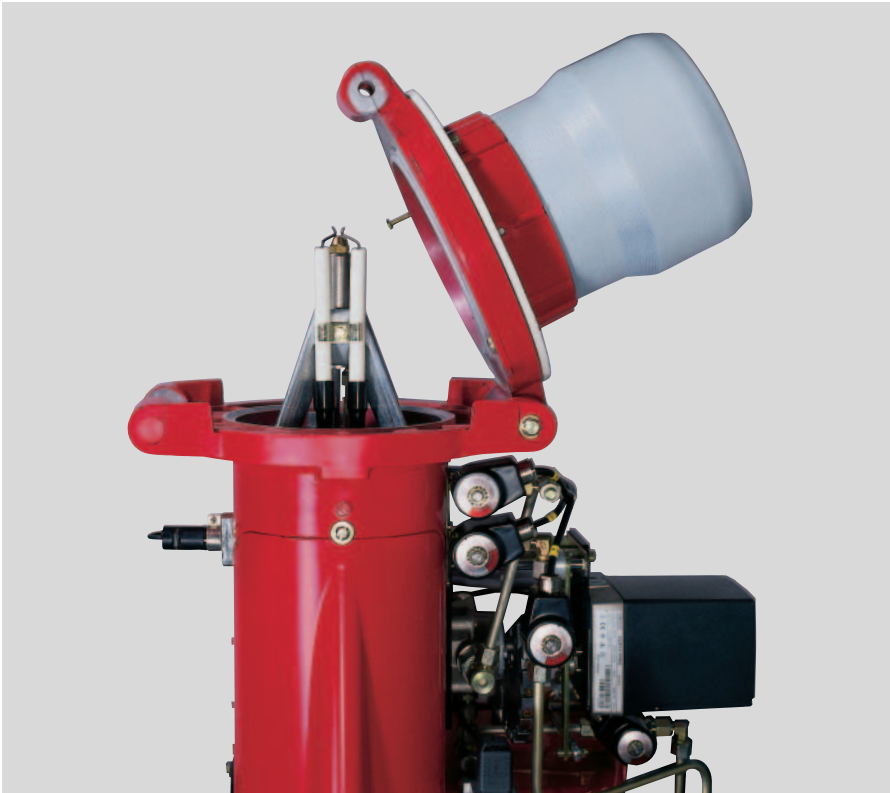

Hinged burner casing

The hinged flange offers many advantages. Combustion head, nozzles and ignition electrodes are easily accessed, which simplifies installation and servicing. The burner can be hinged open after the central screw on the burner flange is released. The design of the heating appliance may necessitate a combustion head extension (e.g. reverse flame boilers). In this case the burner can be hinged open only after disconnecting the ignition and oil lines.

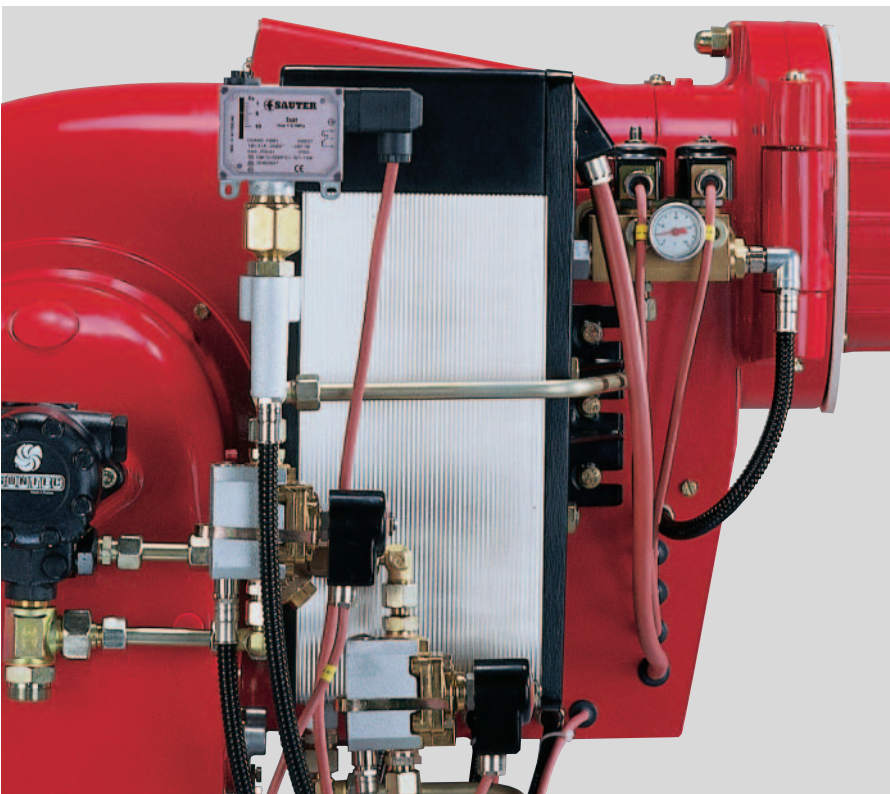

Oil temperature regulation

Residual oil burners are fitted with an oil preheater (electric or media preheater). The oil is quickly heated to the required atomising temperature, due to the large heat exchange surface combined with a relatively small oil volume. The rapid heat distribution prevents local overheating and carbonisation of the oil. Weishaupt manufacture electric and media preheaters as well as combined electric/media preheater assemblies (further information on page 29).

Burner fuel systems

-weishaupt-

L5Z / L7Z

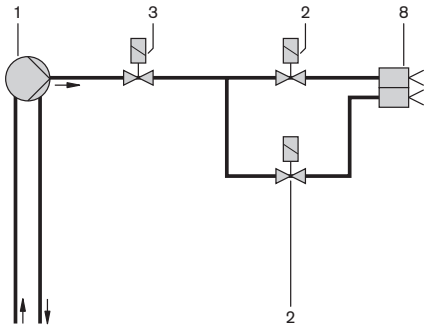

L8Z / L8Z/2

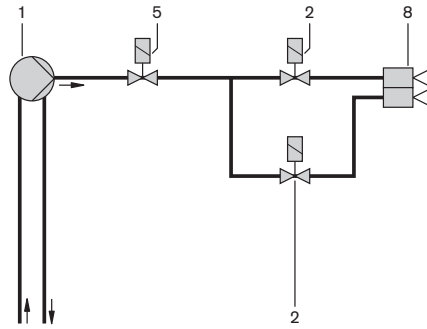

L9Z

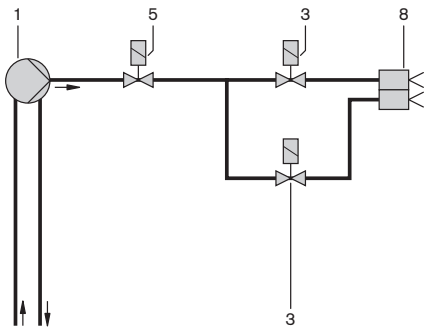

L5T / L7T

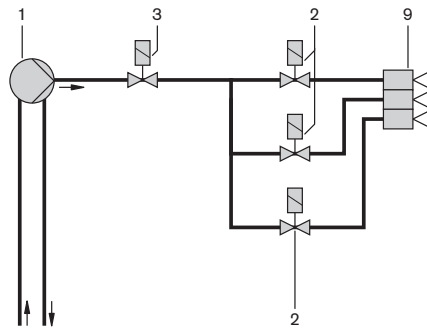

L8T / L8T/2

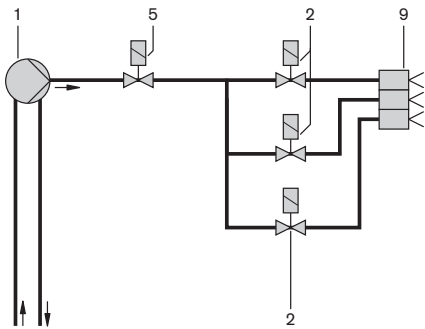

L9T / L10T

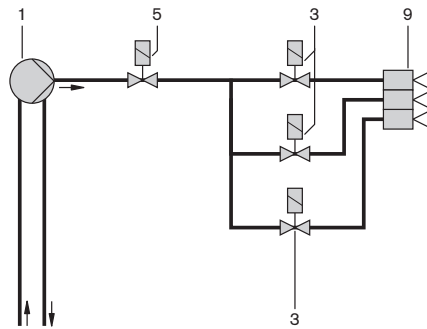

RL5 to RL7

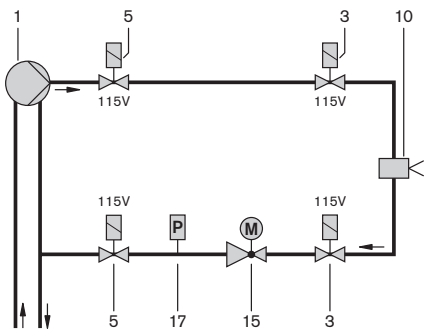

RL8 to RL11

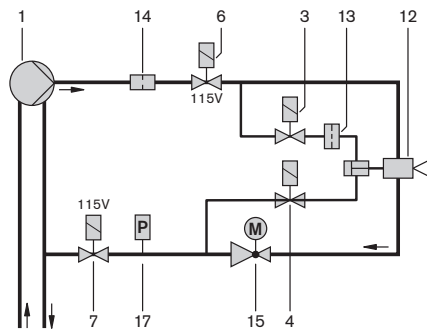

M5Z

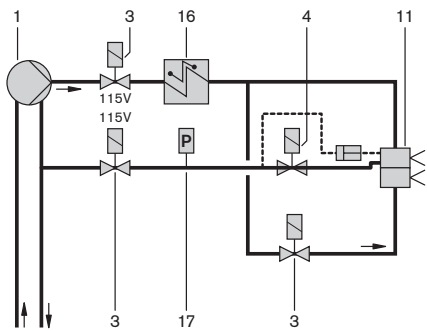

MS7Z to MS9Z

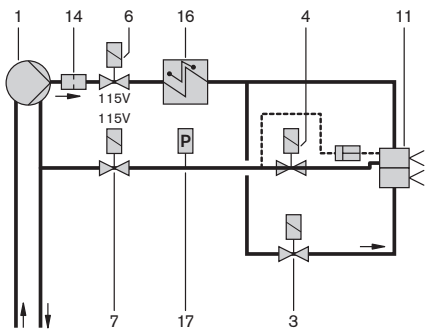

RMS7 to RMS11

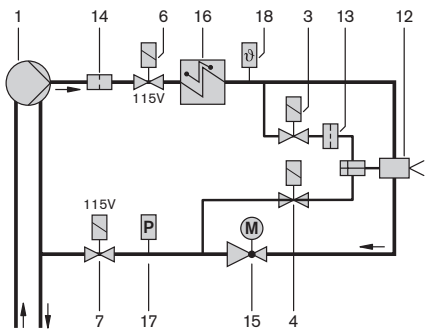

■ **Burner types RL5 - RL7**

Both the solenoid valves marked (3) are electrically connected in series, as are both solenoid valves marked (5). Solenoid valves (3) and (5) in the return are fitted against the direction of flow.

■ **Burner types RL8 - RL11**

Solenoid valve (6) in the flow and (7) in the return are electrically connected in series. Solenoid valve (7) in the return is fitted against the direction of flow.

■ **Burner types M5Z, MS7Z - MS9Z, RMS7 - RMS11**

Solenoid valve (5) / (6) in the flow and (5) / (7) in the return are electrically connected in series. Solenoid valve (5) / (7) in the return is fitted against the direction of flow.

Index

- | | | |
|----|--|-----------|
| 1 | Pump | |
| 2 | Solenoid valve | Coil 9 W |
| | type 7121ZBG1KRTO | |
| | (normally closed) G 1/8 | |
| 3 | Solenoid valve type 121K2423 | Coil 19 W |
| | (normally closed) G 1/8 | |
| 4 | Solenoid valve type 122K9321 | Coil 19 W |
| | (normally open) G 1/8 | |
| 5 | Solenoid valve type 121K6220 | Coil 20 W |
| | (normally closed) G 1/4 | |
| 6 | Solenoid valve type 321H2322 | Coil 20 W |
| | (normally closed) G 3/8 | |
| 7 | Solenoid valve type 121G2320 | Coil 20 W |
| | (normally closed) G 3/8 | |
| 8 | Two stage EL nozzle assembly (without integral shut off device) | |
| 9 | Three stage EL nozzle assembly (without integral shut off device) | |
| 10 | R nozzle assembly (without integral shut off device) | |
| 11 | Two stage M nozzle assembly (with integral shut off device) | |
| 12 | R nozzle assembly (with integral shut off device in flow and return) | |
| 13 | Restricting orifice | |
| 14 | Filter | |
| 15 | Oil regulator | |
| 16 | Oil preheater | |
| 17 | 0 - 10 bar pressure switch in return (set to 5 bar for EL, 7 bar for MS) | |
| 18 | Temperature sensor | |

The stated voltages are with 230 V control voltage. 115 V and 55 V devices are used with 115 V control voltage.

Burner selection - rating / combustion chamber pressure

Monarch types L and RL

– weishaupt –

Size 5

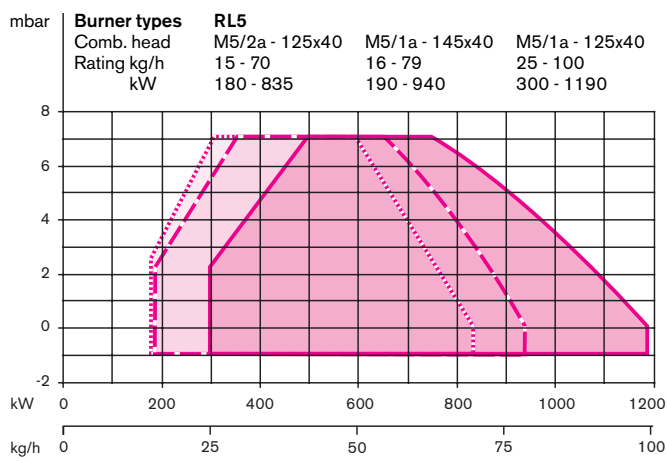
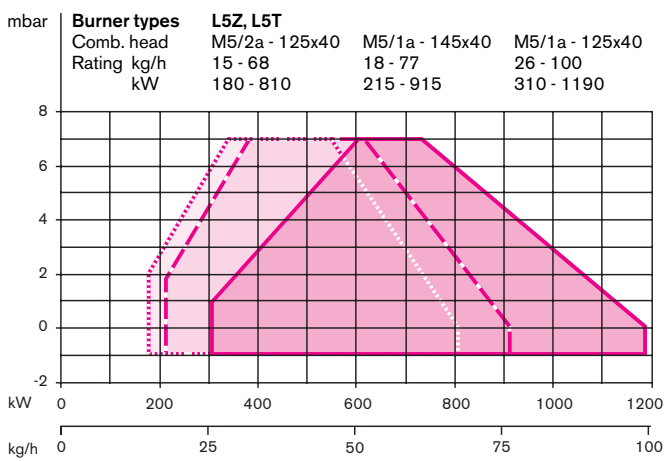

The capacities in relation to combustion chamber resistances are maximum values, which were measured to DIN 4787 Part 1 / EN 267 on idealised test flame tubes.

All ratings data given relate to an air temperature of 20°C and an installation height above sea level of 500 m.

The oil throughput information refers to a calorific value of :
 11.91 kWh/kg for distillate oil EL
 11.62 kWh/kg for residual oil M
 11.24 kWh/kg for residual oil S

Size 7

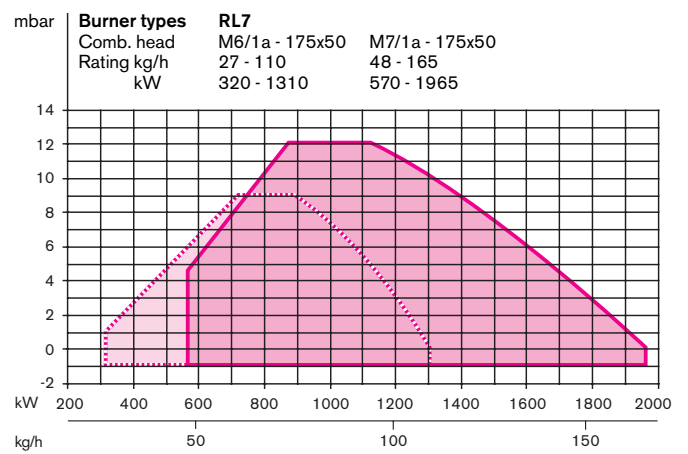
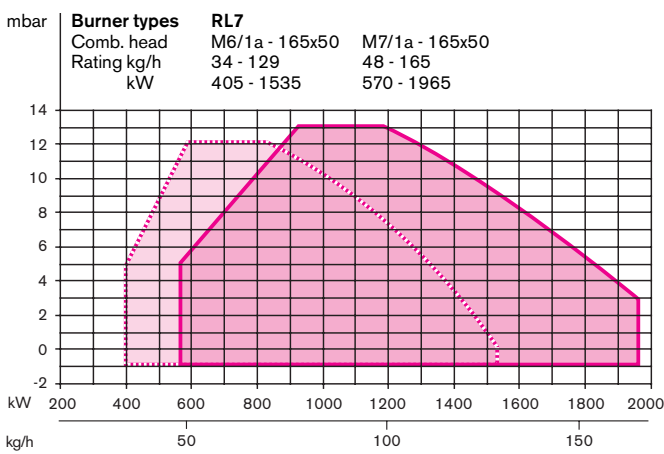
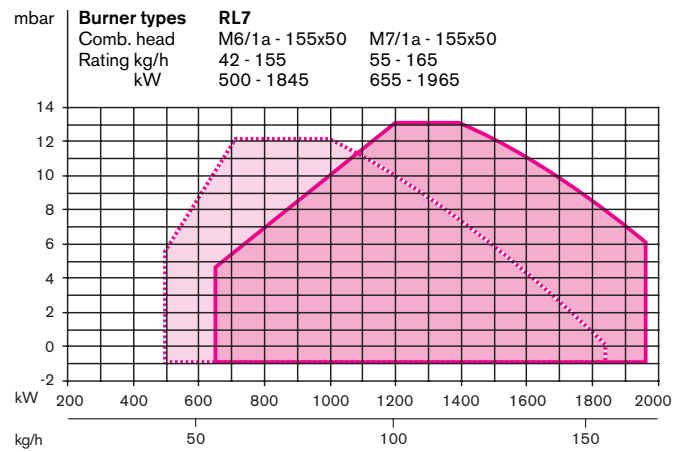
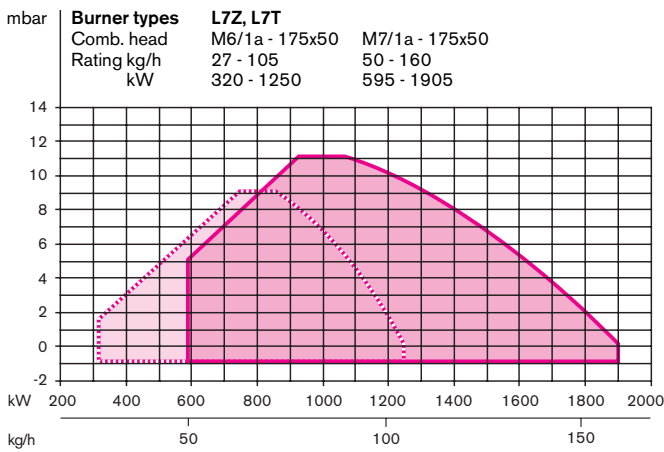
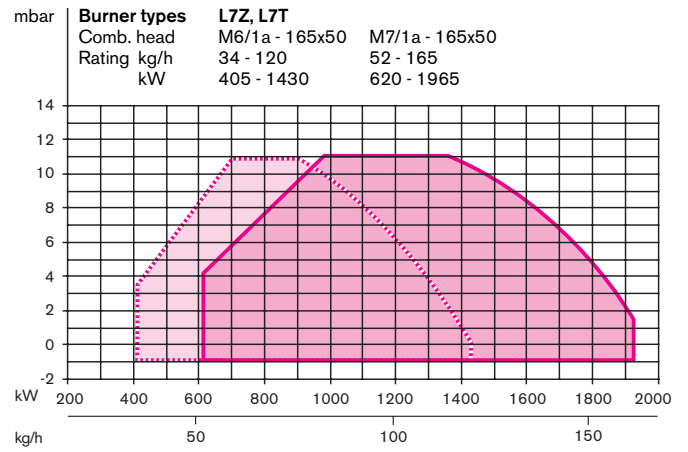
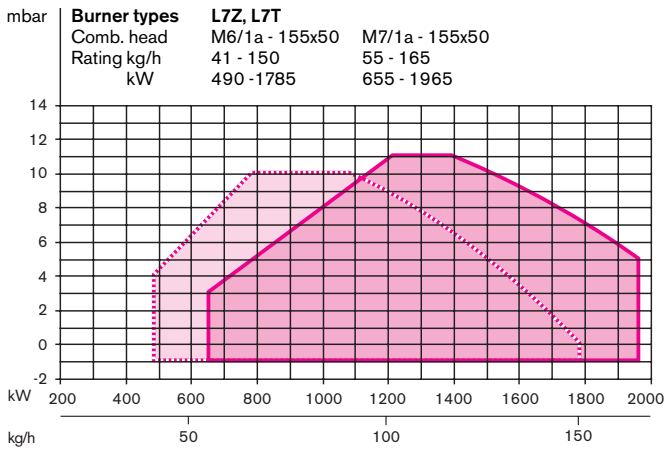

Burner selection - rating / combustion chamber pressure Monarch types L and RL

- weishaupt -

Size 8

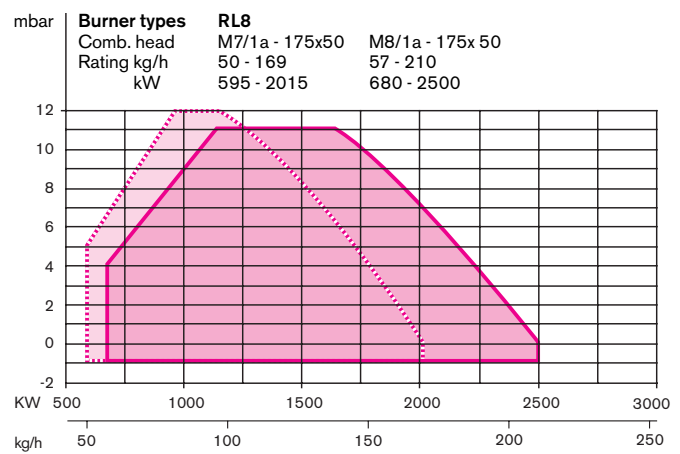
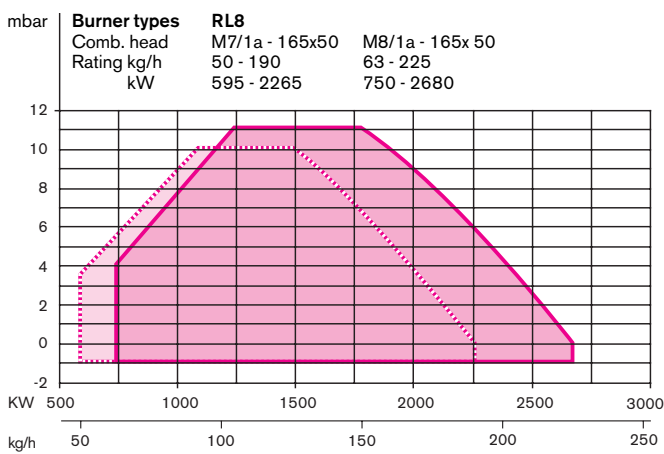
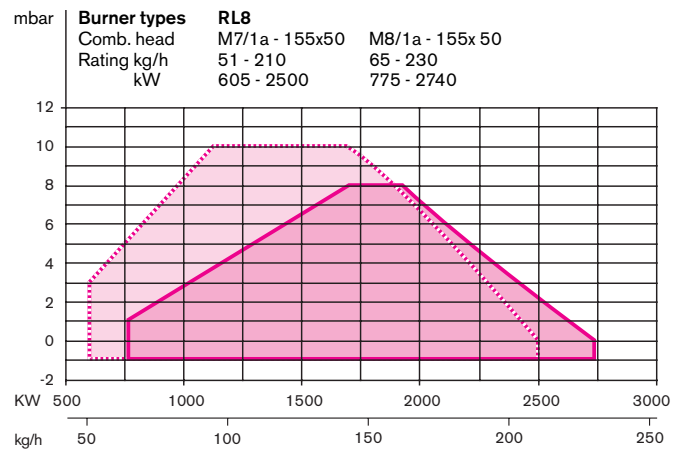
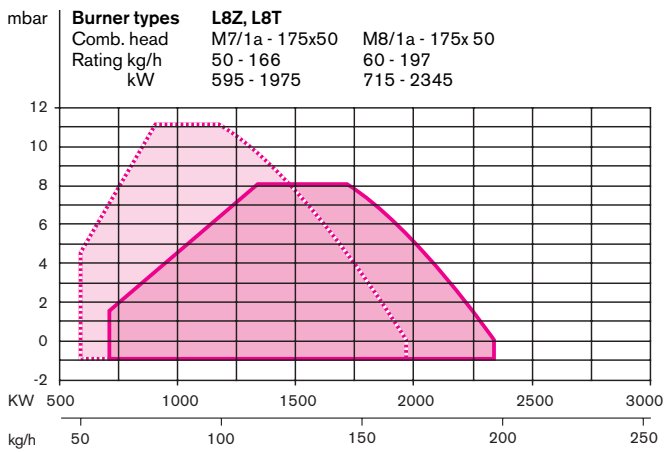
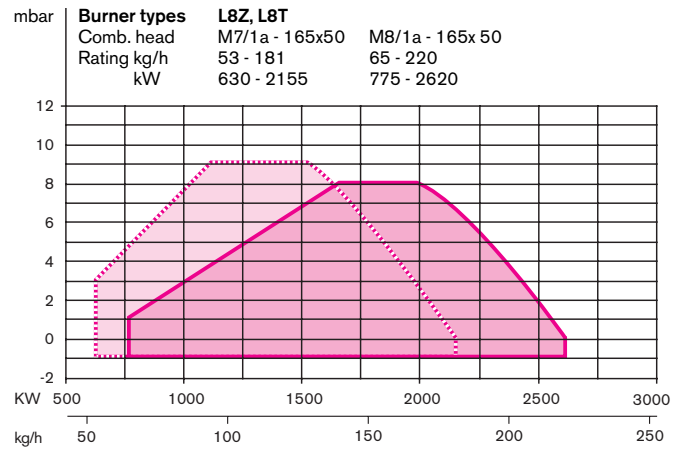
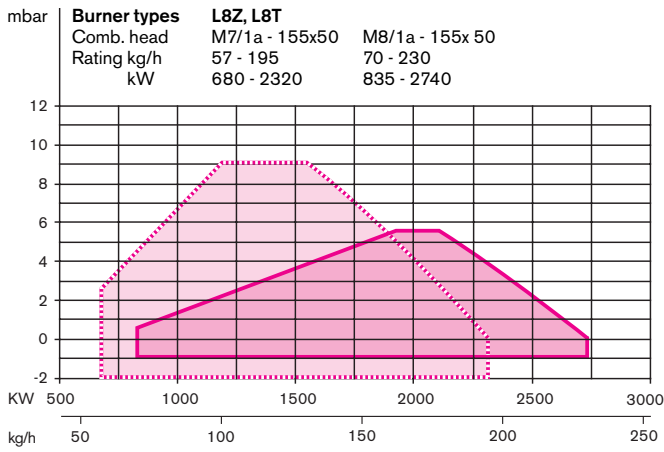

Size 8/2

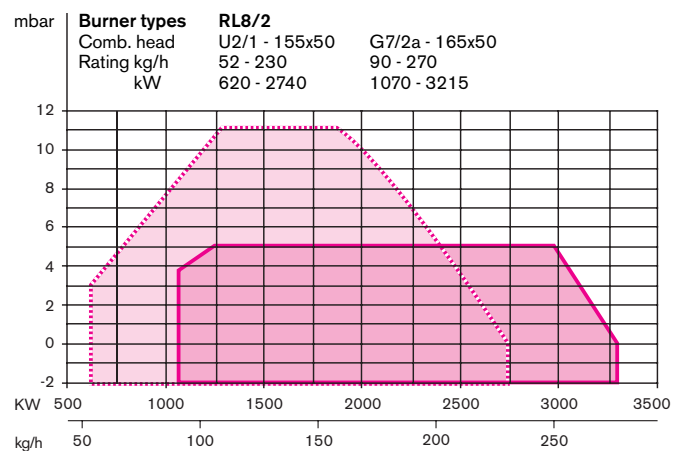
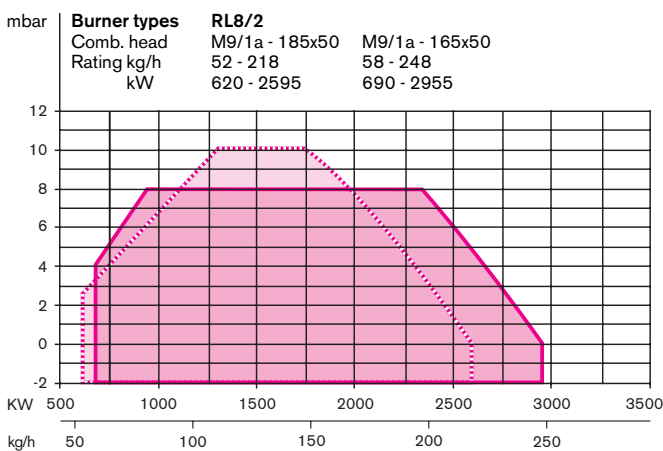
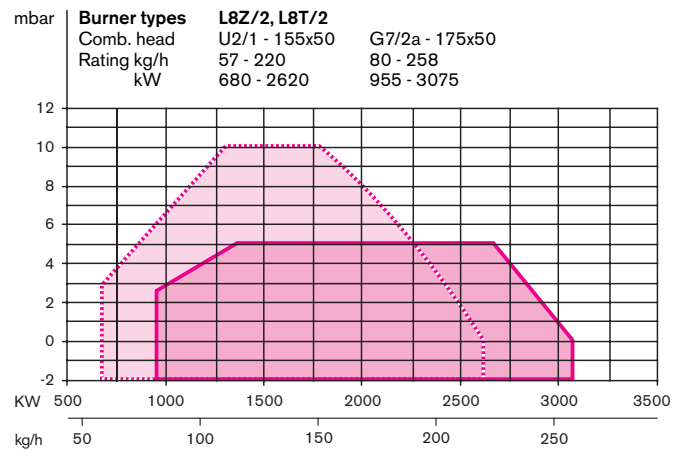
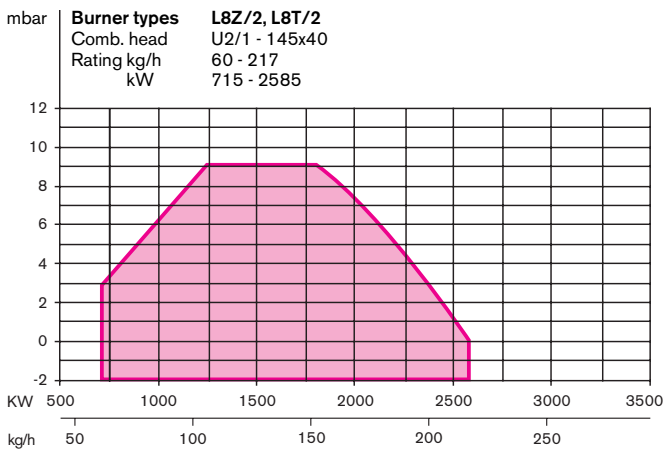
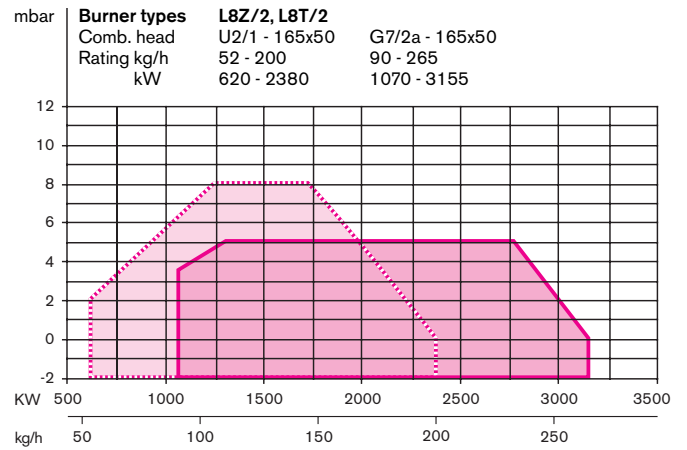
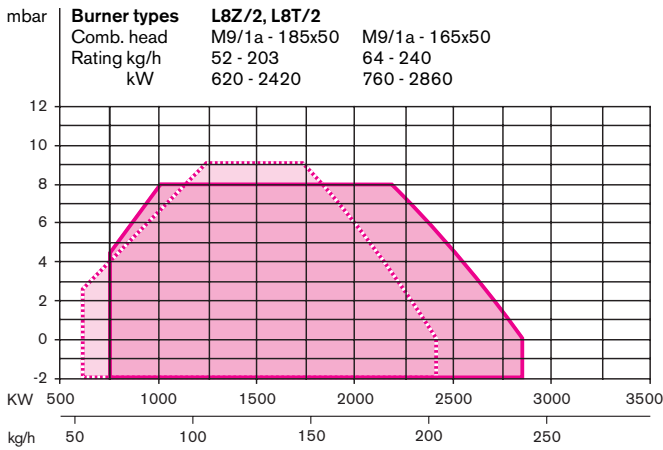

Burner selection - rating / combustion chamber pressure Monarch types L and RL

-weishaupt-

Size 8/2

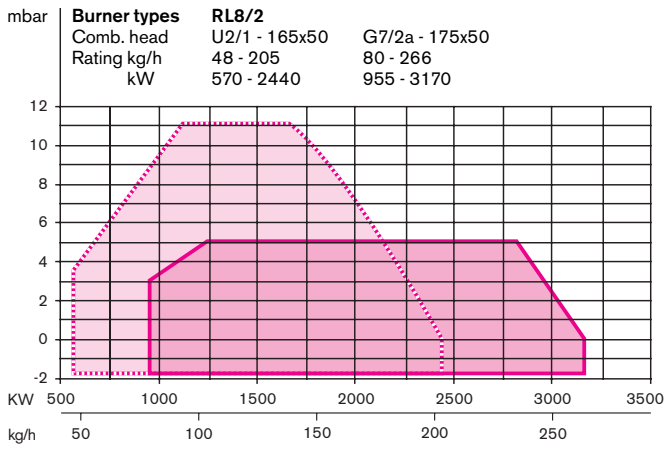

Size 9

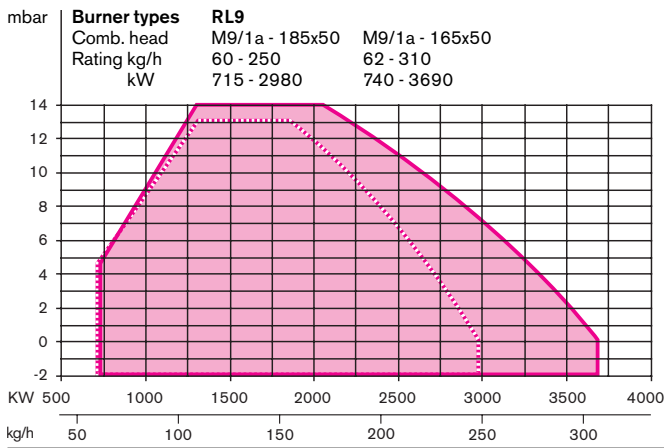
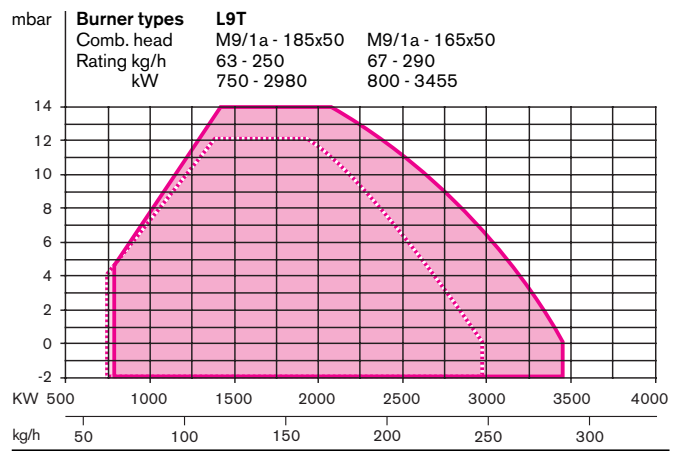
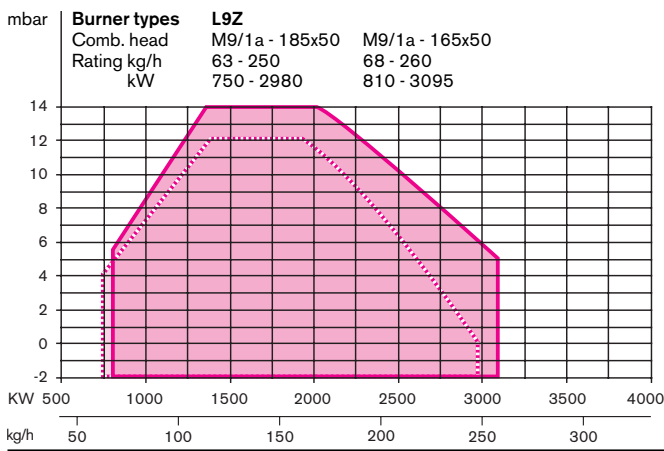

Sizes 10 and 11

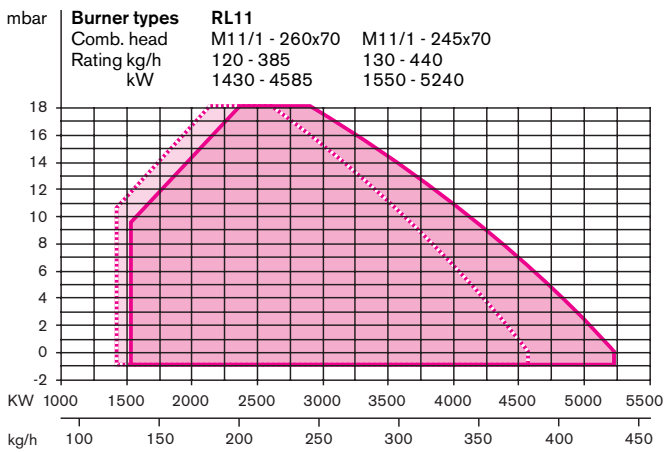
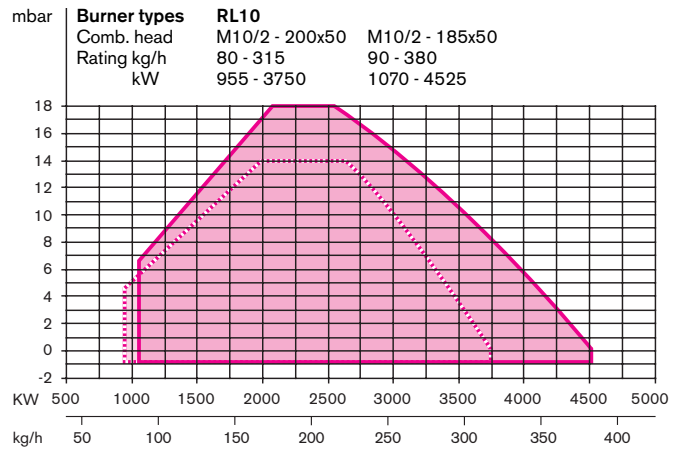
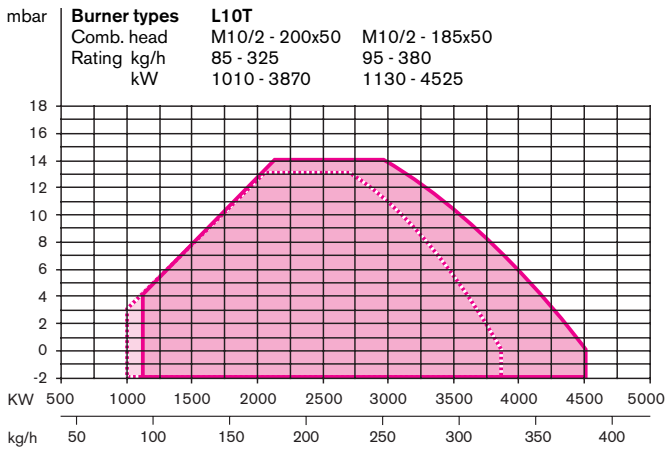

Burner selection - rating / combustion chamber pressure Monarch types M/MS and RMS

– weishaupt –

Size 5

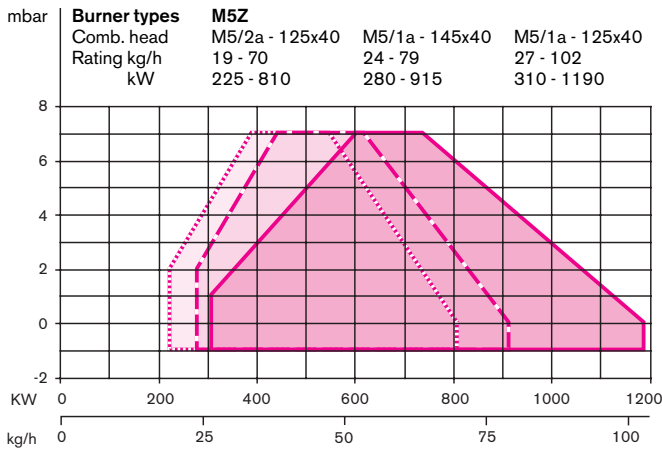

Notes on MS and RMS burners

Residual oil burners cannot be used in the Federal Republic of Germany. The data presented in these capacity graphs are maximal values. The values actually achievable are dependent on the combustion chamber and should be calculated from measurements on the heating appliance concerned.

Combustion of residual oil

For MS and RMS type oil burners the oil throughput in relation to nominal rating must not be less than 100 kg/h. It is also recommended that sliding two stage RMS type burners are used when burning this fuel.

Size 7

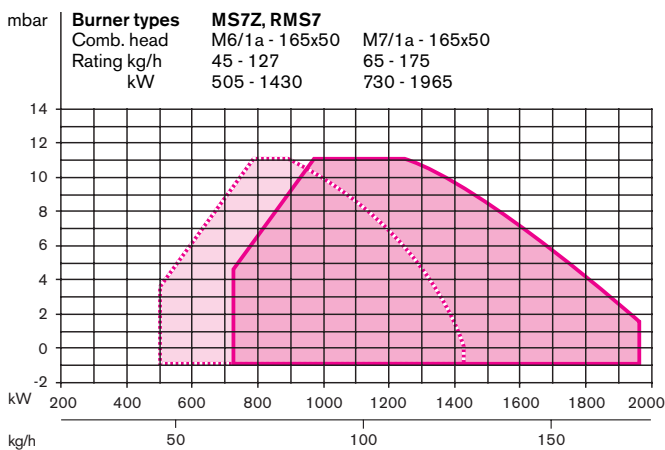
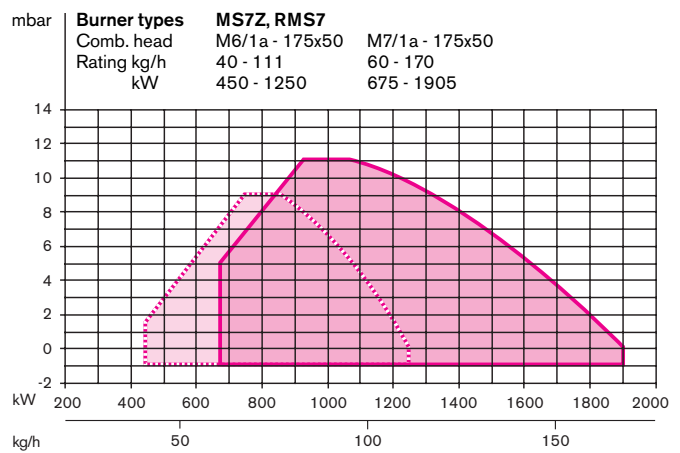
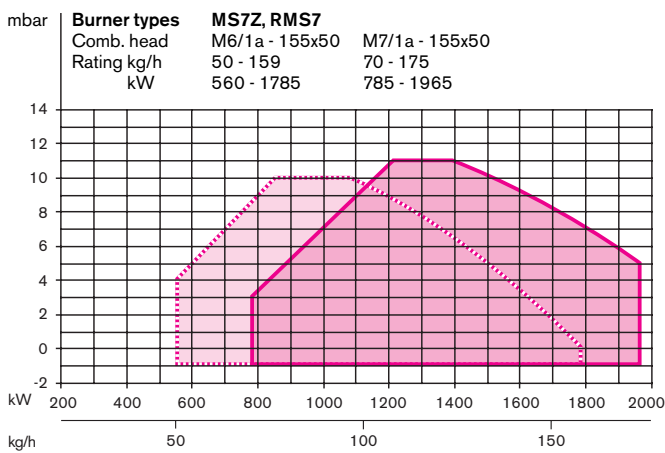

Size 8

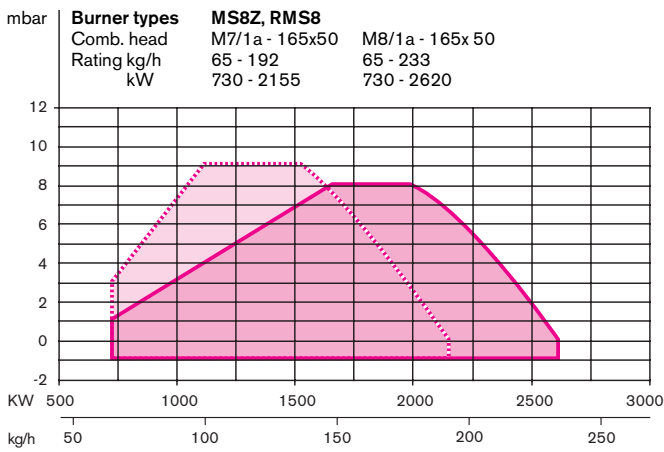
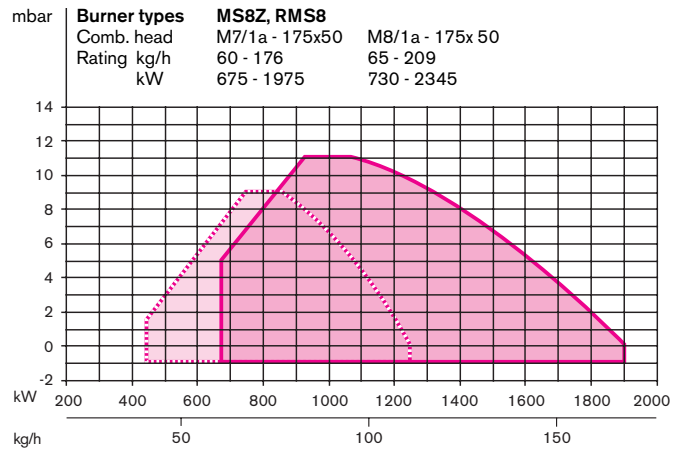
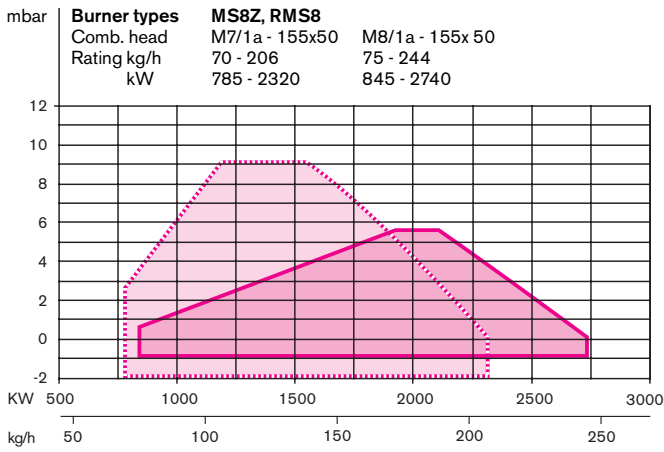

Burner selection - rating / combustion chamber pressure Monarch types M/MS and RMS

–weishaupt–

Size 8/2

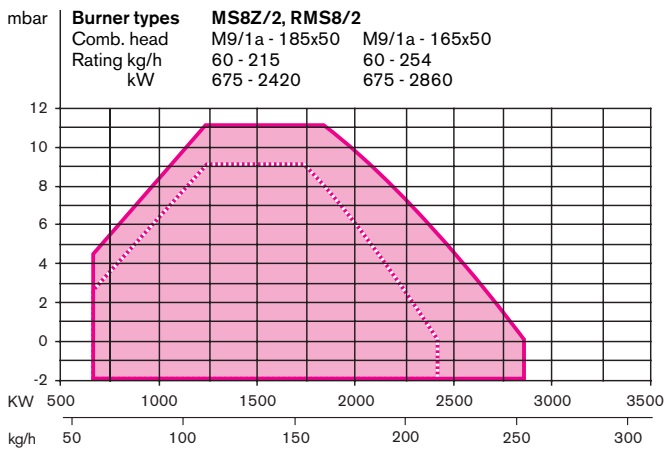
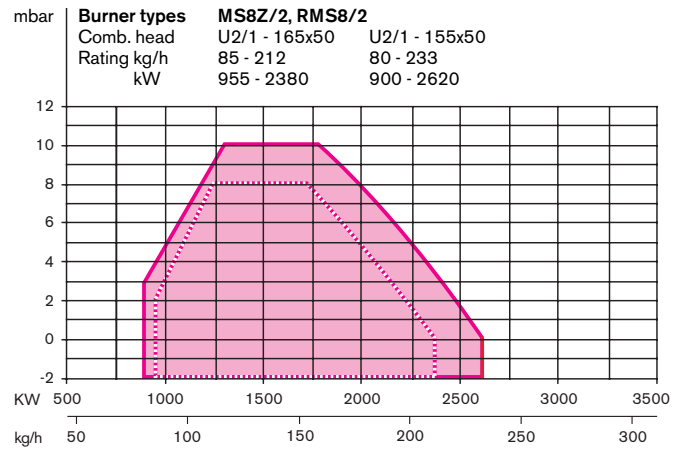
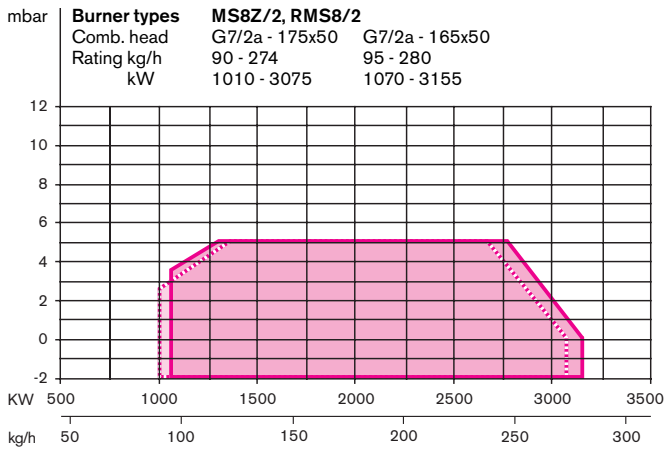

Size 9

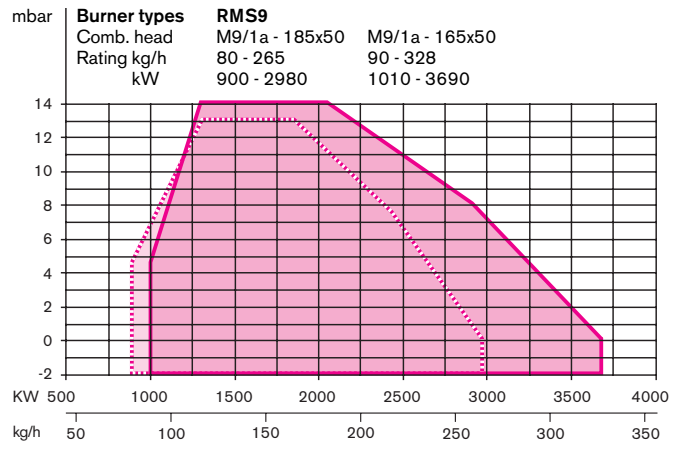
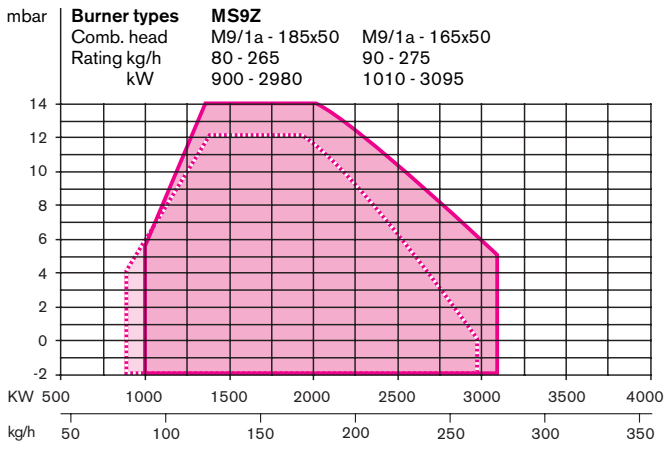

Sizes 10 and 11

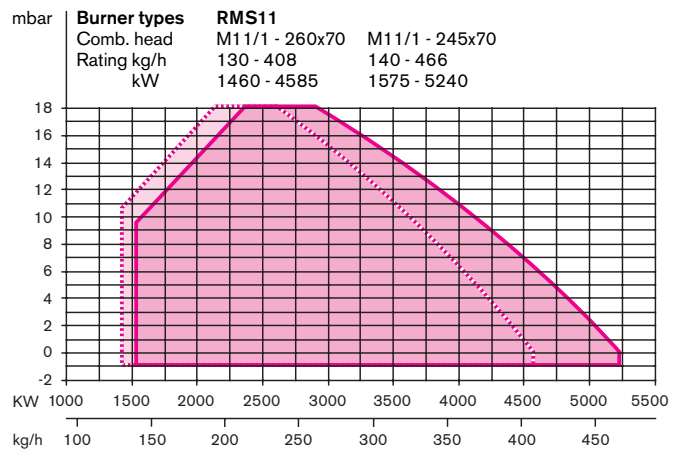
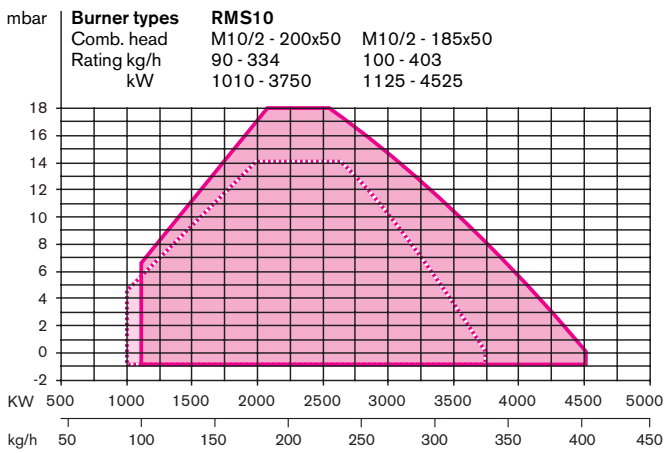

Technical data

Monarch types L and RL

– weishaupt –

Burner type	Version	With int. switchgear Order No.	Without int. switchgear Order No.	Type test No.	Burner controller	Pump	Fan wheel	Servomotor
L5Z	D	611 564 01 ^③	611 564 02	5G553/05	LAL2...	J6	Ø 248x100	-w- 1055/23
L7Z	D	611 764 01 ^③	611 764 02	5G581/05	LAL 2...	J6	Ø 268x100	-w- 1055/23
L8Z	D	611 864 01 ^③	611 864 02	5G595/2006	LAL 2...	J6/J7 ^①	Ø 268x100	-w- 1055/23
L8Z/2	D	611 866 01 ^③	611 866 02	5G595/2006	LAL 2...	J6/J7/TA2 ^{①②}	Ø 268x100	-w- 1055/23
L9Z	D	611 964 01 ^③	611 964 02	5G601/2006	LAL 2...	J6/J7/TA2 ^{①②}	Ø 330x100	-w- 1055/23
L5T	D	611 594 01 ^③	611 594 02	5G553/05	LAL 2...	J6	Ø 248x100	-w- 1055/80
L7T	D	611 794 01 ^③	611 794 02	5G581/05	LAL 2...	J6	Ø 268x100	-w- 1055/80
L8T	D	611 894 01 ^③	611 894 02	5G595/2006	LAL 2...	J6/J7 ^①	Ø 268x100	-w- 1055/80
L8T/2	D	611 896 01 ^③	611 896 02	5G595/2006	LAL 2...	J6/J7/TA2 ^{①②}	Ø 268x100	-w- 1055/80
L9T	D	611 994 01 ^③	611 994 02	5G601/2006	LAL 2...	J6/J7/TA2 ^{①②}	Ø 330x100	-w- 1055/80
L10T	D	–	681 094 02	5G604/2006	LAL 2...	J7/TA2 ^②	Ø 345x100	-w- 1055/80
RL5	ZMD	–	611 574 03	5G579/05	LAL 2...	J6	Ø 248x100	SQM ^④
RL7	ZMD	–	611 774 03	5G583/05	LAL 2...	TA2	Ø 268x100	SQM ^④
RL8	ZMD	–	611 874 02	5G597/2006	LAL 2...	TA3	Ø 268x100	SQM ^④
RL8/2	ZMD	–	611 876 02	5G597/2006	LAL 2...	TA3	Ø 268x100	SQM ^④
RL9	ZMD	–	611 974 02	5G603/2006	LAL 2...	TA3	Ø 330x100	SQM ^④
RL10	ZMD	–	681 074 02	5G605/2006	LAL 2...	TA3	Ø 345x100	SQM ^④
RL11	ZMD	–	681 174 02	5G606/2006	LAL 2...	TA4	Ø 345x100	SQM ^④

Voltages and frequencies

The burners are supplied with three phase 400 V, 50 Hz supply (D) as standard. Please indicate other voltages and frequencies required (no extra price).

Burner motor standard version

Insulation class F, to IP54.

Modulating burners

The modulating burners are based on the sliding two stage burners. The modulating feature is obtained by fitting a suitable electrical controller into the panel (also see page 3).

Burners without integral switchgear

On burners without integral switchgear, the burner controller is supplied loose. It can be mounted on the burner at extra cost. A terminal strip is provided in both cases.

Burner motor 50 Hz, 2800 rpm	Motor fusing	Oil hoses		Hose side /Installation side connection		Approx. weight kg
		DN	Length mm			
D90/90-2; 3~230/400 V; 1,5 kW; 6,0-3,5 A	10A / 2,0-6,3A ^⑤ 2,5-4,0A ^⑦	13	1000	G1/2"	G1/2"	53
D112/110 - 2/1 3~230/400V; 3,0kW; 10,5/6,0A	16A / 4,5-6,5A ^⑤ 4,0-6,3A ^⑦	13	1000	G1/2"	G1/2"	73
D112/140 - 2/1 3~400V; 4,8kW; 9,5A	25A / 7,5-11,0A ^⑤ 9,0-12,5A ^⑦	13	1000	G1/2"	G1/2"	78
D112/140 - 2/1 3~400V; 4,8kW; 9,5A	25A / 7,5-11,0A ^⑤ 9,0-12,5A ^⑦	13	1000	G1/2"	G1/2"	81
D132/120-2a; 3~400V; 6,5kW; 13,5A	35A / 10,0-14,0A ^⑤ 25A / 6,0-8,5A ^⑥ 12,5-16,0A ^⑦	13	1000	G1/2"	G1/2"	125
D90/90-2; 3~230/400V; 1,5 kW; 6,0/3,5 A	10A / 2,0-6,3A ^⑤ 2,5-4,0A ^⑦	13	1000	G1/2"	G1/2"	53
D112/110 - 2/1 3~230/400V; 3,0kW; 10,5/6,0A	16A / 4,5-6,5A ^⑤ 4,0-6,3A ^⑦	13	1000	G1/2"	G1/2"	73
D112/140 - 2/1 3~400V; 4,8kW; 9,5A	25A / 7,5-11,0A ^⑤ 9,0-12,5A ^⑦	13	1000	G1/2"	G1/2"	78
D112/140 - 2/1 3~400V; 4,8kW; 9,5A	25A / 7,5-11,0A ^⑤ 9,0-12,5A ^⑦	13	1000	G1/2"	G1/2"	81
D132/120-2a; 3~400V; 6,5kW; 13,5 A	35A / 10,0-14,0A ^⑤ 25A / 6,0-8,5A ^⑥ 12,5-16,0A ^⑦	13	1000	G1/2"	G1/2"	125
D132/120-2; 3~400V; 9kW; 18,0 A	16,0-20,0A ^⑦	13/20	1000	G1/2"/M30 x 1,5	G1/2"/G1"	137
D90/90-2; 3~230/400V; 1,5 kW; 6,0/3,5 A	2,5-4,0A ^⑦	13	1000	G1/2"	G1"	60
D112/110-2/1; 3~230/400V; 3,0kW; 10,5/6,0A	4,0-6,3A ^⑦	20	1000	M 30 x 1,5	G1"	80
D112/140-2/1; 3~400V; 4,8kW; 9,5A	9,0-12,5A ^⑦	20	1000	M 30 x 1,5	G1"	85
D112/140-2/1; 3~400V; 4,8kW; 9,5A	9,0-12,5A ^⑦	20	1000	M 30 x 1,5	G1"	89
DK132/120-2a; 3~400V; 6,5kW; 13,5A	12,5-16,0A ^⑦	20	1000	M 30 x 1,5	G1"	132
D132/120-2; 3~ 400V; 9kW; 18,0A	16,0-20,0A ^⑦	20	1000	M 30 x 1,5	G1"	137
D132/150-2; 3~ 400V; 12 kW; 23,0A	20,0-25,0A ^⑦	25	1300	M 38 x 1,5	G1"	195

① Additional price for burners over 140 kg/h oil: Pump J7 in lieu of J6 (see page 24)

② Additional price for burners over 220 kg/h oil: Pump TA2 in lieu of J7 (see page 24)

③ A separate control panel is required on installations to TRD 411 or TRD 604. The integral switchgear is therefore omitted.

④ For sliding two stage (ZM) burners: SQM 10.15562 servomotor (20 s)
For modulating (M) burners: SQM 10.16562 servomotor (42 s)

⑤ With integral switchgear Prefusing/overload relay D.O.L. start

⑥ With integral switchgear Prefusing/overload relay \checkmark V start

⑦ Without integral switchgear Motor protection switch D.O.L. and \checkmark V start

Note: If the supply pressure is > 2 bar, pump E6 instead of J6, or E7 instead of J7 should be used.

Technical data

Monarch types M/MS and RMS

– weishaupt –

Burner type	Version	With int. switchgear Order No.	Without int. switchgear Order No.	Burner controller	Pump	Fan wheel	Oil preheater	Servomotor
M5Z	D	612 564 03	612 564 04	LAL2...	E4	Ø 248x100	EV2B/4,5kW	-w- 1055/23
MS7Z	D	612 764 03	612 764 04	LAL 2...	E6	Ø 268x100	EV2D/13,2kW ②	-w- 1055/23
MS8Z	D	612 864 03	612 864 04	LAL 2...	E7	Ø 268x100	EV2D/13,2kW	-w- 1055/23
MS8Z/2	D	612 866 03	612 866 04	LAL 2...	E7	Ø 268x100	EV2D/13,2kW ③	-w- 1055/23
MS9Z	D	–	612 964 04	LAL 2...	E7	Ø 330x100	EV2D/13,2kW ③	-w- 1055/23
RMS7	ZMD	–	612 774 03	LAL 2...	TA2	Ø 268x100	EV2D/13,2kW ②	SQM ⑤
RMS8	ZMD	–	612 874 04	LAL 2...	TA3	Ø 268x100	EV2D/13,2kW	SQM ⑤
RMS8/2	ZMD	–	612 876 04	LAL 2...	TA3	Ø 268x100	EV2D/13,2kW ③	SQM ⑤
RMS9	ZMD	–	612 974 04	LAL 2...	TA3	Ø 330x100	EV2D/13,2kW ③④	SQM ⑤
RMS10	ZMD	–	682 074 04	LAL 2...	TA3	Ø 345x100	EV2D/13,2kW ③④	SQM ⑤
RMS11	ZMD	–	682 174 03	LAL 2...	TA4	Ø 345x100	WEV3/22,4kW	SQM ⑤

Voltages and frequencies

The burners are supplied with three phase 400 V, 50 Hz supply (D) as standard. Please indicate other voltages and frequencies required (no extra price).

Burner motor standard version

Insulation class F, to IP54.

Combustion of heavy oil

The oil throughput of **type MS and RMS** heavy oil burners, referenced to the nominal capacity, must be no less than 100 kg/h. Furthermore the use of RMS type burners is recommended when combusting this fuel.

RMS type burners

For the combustion of residual oil with a viscosity in excess of 50 mm²/s at 100°C please enquire.

Modulating burners

The modulating burners are based on the sliding two stage burners. The modulating feature is obtained by fitting a suitable electrical controller into the panel (also see page 3).

Burner motor 50 Hz, 2800 rpm	Motor fusing	Oil hoses		Hose side / connection	Installation side connection	Approx. weight kg
		DN	Length mm Flow / Return			
D90/90-2; 3~230/400 V; 1,5 kW; 6,0-3,5 A	10A / 2,0-6,3A ⑥ 2,5-4,0A ⑦	12	1000 / 700	G1/2"	G1/2"	68
D112/110 - 2/1 3~230/400V; 3,0kW; 10,5/6,0A	16A / 4,5-6,5A ⑥ 4,0-6,3A ⑦	20	1300 / 1000	M 30 x 1,5	G1"	94
D112/140 - 2/1 3~400V; 4,8kW; 9,5A	25A / 7,5-11,0A ⑥ 9,0-12,5A ⑦	20	1300 / 1000	M 30 x 1,5	G1"	112
D112/140 - 2/1 3~400V; 4,8kW; 9,5A	25A / 7,5-11,0A ⑥ 9,0-12,5A ⑦	20	1300 / 1000	M 30 x 1,5	G1"	115
D132/120-2a; 3~400V; 6,5kW; 13,5A	12,5-16,0A ⑦	20	1300 / 1000	M 30 x 1,5	G1"	144
D112/110 - 2/1; 3~230/400V; 3,0kW; 10,5/6,0A	4,0-6,3A ⑦	20	1300 / 1000	M 30 x 1,5	G1"	111
D112/140 - 2/1; 3~400V; 4,8kW; 9,5A	9,0-12,5 ⑦	20	1300 / 1000	M 30 x 1,5	G1"	120
D112/140 - 2/1; 3~400V; 4,8kW; 9,5A	9,0-12,5 ⑦	20	1300 / 1000	M 30 x 1,5	G1"	124
DK132/120-2a; 3~400V; 6,5kW; 13,5A	12,5-16,0A ⑦	20	1300 / 1000	M 30 x 1,5	G1"	175
D132/120-2; 3~400V; 9kW; 18,0A	16,0-20,0A ⑦	20	1300 / 1000	M 30 x 1,5	G1"	180
D132/150-2; 3~400V; 12kW; 23,0A	20,0-25,0A ⑦	25	1500 / 1150	M 38 x 1,5	G1"	245

② Price reduction available for $\leq 152 \text{ mm}^2/\text{s}$ at 50C:
Oil preheater EV2C

③ Additional price for burners over 270 kg/h oil:
Oil preheater WEV2.2 in lieu of EVD2D - see special equipment.

④ Additional price for burners over 300 kg/h oil:
Oil preheater WEV3 in lieu of WEV2.2 - see special equipment.

⑤ For sliding two stage (ZM) burners:
SQM 10.15562 servomotor (20 s)
For modulating (M) burners:
SQM 10.16562 servomotor (42 s)

⑥ With integral switchgear
Prefusing/overload relay
D.O.L. start

⑦ Without integral switchgear
Motor protection switch
D.O.L. and \checkmark start

Special equipment

Monarch L, M and MS, two and three stage

–weishaupt–

No.	Description		5 Order No.	7 Order No.	
1	Hours counter ① in integral switchgear	1 x L...Z	110 011 75	110 011 76	
		2 x L...Z	110 001 07	110 001 08	
		1 x L...T	110 014 40	110 013 43	
2	Pump	L...Z+T	J7 in lieu of J6 (L burners) TA2 in lieu of J6 ② (L burners)	–	
		L...T	TA2 in lieu of J7	–	
		L...Z+T	E6 in lieu of J6 for ring main pressure > 2,0 bar	110 017 22	110 017 22
		L...Z+T	E7 in lieu of J7 for ring main pressure > 2,0 bar	–	–
3	Heating	for pump E	110 004 74	110 004 74	
4	Pressure gauge with isolating valve	L...Z+T	J-pump TA-pump E-pump	110 000 79	
		M/MS...Z	–	110 008 82	
5	Vacuum gauge with isolating valve	L...Z+T	J-pump TA-pump E-pump	110 005 69	
		M/MS...Z	–	110 005 70	
6	Magnetic clutch for post purge	L...Z+T	J-pump TA-pump E-pump	110 003 36	
		M/MS...Z	–	110 003 32	
7	Magnetic clutch for post purge to relieve pressure	for L burners	–	110 003 97	
		for M/MS burners	–	110 007 28	
8	Combustion head extensions	L...Z	100 mm	110 000 29	
			150 mm	–	
			200 mm	110 000 37	
		L...T	100 mm	–	
			150 mm	110 013 86	
			200 mm	110 014 18	
M/MS...Z	100 mm	–			
	150 mm	–			
	200 mm	110 016 73			
9	Oil meter fitted	for L...Z burners	110 013 46	110 013 47	
		for L...T burners	110 014 60	110 013 48	
10	Oil preheater MV9C for MS burners in addition to standard electric oil preheater, inc. oil connection parts and thermometer	–	–	110 008 26	
11	Oil preheater MV9C in lieu EV2D inc. oil connection parts with temp. cont. for oil release.	–	–	110 001 18	
12	Vertically firing burner with media preheaters only (MV rotated through 90 because of condensate)	–	–	110 000 52	
13	Fittings media preheater with electric preheater – screwed for warm water – flanged for hot water – screwed for low pressure steam – screwed for high pressure steam – screwed for high pressure steam – flanged for high pressure steam – flanged for high pressure steam – flanged for thermal fluid – flanged for thermal fluid	up to 110°C über 110°C up to 180 °C	110 001 25	110 001 25	
			110 001 28	110 001 28	
		up to 0,5 bar up to 1,5 bar from 1,5 bar up to 15 bar	110 001 29	110 001 29	
			110 001 29	110 001 29	
			110 001 31	110 001 31	
		from 6 bar up to 20 bar from 20 bar up to 25 bar	110 001 32	110 001 32	
			110 001 24	110 001 24	
		up to 250°C up to 300°C	110 001 33	110 001 33	
			110 001 34	110 001 34	
		14	Fittings media preheater without electric preheater with thermostat valve – flanged for hot water – screwed for high pressure steam – screwed for high pressure steam – flanged for high pressure steam – flanged for thermal fluid – flanged for thermal fluid	from 110°C up to 180°C from 7,5 bar up to 13 bar from 13 bar up to 20 bar	110 001 61
110 001 62	110 001 62				
110 001 63	110 001 63				
from 20 bar up to 25 bar up to 250°C up to 300°C	110 001 66			110 001 66	
	110 001 64			110 001 64	
	110 001 65			110 001 65	
15	Oil hoses 1300 in lieu of 1000 mm long heated (stainless steel)	for L burners	110 000 72	110 000 72	
		for M/MS burners	110 010 17	110 010 18	
16	Burener controller	LAL 2.14	110 006 03	110 006 03	
		LAL 2.65	110 006 04	110 006 04	
		LAL 3.25	110 006 48	110 006 48	
		LOK 16.250	110 013 06	110 013 06	
		–	–	–	
Price reductions					
17	Oil preheater	EV2C in lieu of EV2D EV2C in lieu of EV2D	MS7Z with integral switchgear – MS7Z without integral switchgear	– –	
				110 004 70 110 009 79	

Burners supplied to TRD 411 and TRD 604
See special information (available on request).

Ships' execution
See separate price list

No.	8 Order No.	8/2 Order No.	9 Order No.	10 Order No.	11 Order No.
1	110 011 76 110 001 08 110 013 43	110 011 76 110 001 08 110 013 43	- 110 013 22 110 015 49	- - -	- - -
2	- 110 015 43 -	110 015 43 110 004 46 -	110 015 43 110 006 45 -	- 110 015 46 110 015 46	- - -
	110 017 22	110 017 22	110 017 22	-	-
	110 015 44	110 015 44	110 015 44	110 015 44	-
3	110 004 74	110 004 74	110 004 74	-	-
4	110 000 79 110 008 82	110 000 79 110 002 82 110 008 82	110 000 79 110 002 82 110 008 82	- 110 002 82 -	- - -
5	110 005 69 110 005 70	110 005 69 110 017 00 110 005 70	110 005 69 110 017 00 110 005 70	- 110 017 00 -	- - -
6	110 003 37 110 009 77	110 003 37 110 004 03 110 009 77	110 003 38 110 004 03 -	- 180 001 02 -	- - -
7	110 015 86 110 015 97	110 015 86 110 015 97	- 110 005 65	110 009 92 -	- -
8	- 110 000 34 110 000 42	- 110 000 46 110 000 43	- 110 006 75 110 006 98	- - -	- - -
	- 110 005 93 110 005 94	- 110 005 95 110 005 96	- 110 005 97 110 005 98	- 180 000 44 180 000 45	- - -
	- 110 010 83 110 010 84	- 110 010 85 110 010 86	- 110 010 87 110 010 88	- - -	- - -
9	110 013 55 110 013 56	110 013 55 110 013 56	110 013 57 110 013 58	- 180 001 22	- -
10	110 008 26	110 008 25	110 008 24	-	-
11	110 001 18	-	110 010 62	-	-
12	110 000 52	110 000 52	110 000 52	-	-
13	110 001 25 110 001 28	110 001 25 110 001 28	110 001 25 110 001 28	- -	- -
	110 001 29 110 001 29 110 001 31	110 001 29 110 001 29 110 001 31	110 001 29 110 001 29 110 001 31	- - -	- - -
	110 001 32 110 001 24	110 001 32 110 001 24	110 001 32 110 001 24	- -	- -
	110 001 33 110 001 34	110 001 33 110 001 34	110 001 33 110 001 34	- -	- -
14	110 001 61 110 001 62 110 001 63	110 001 61 110 001 62 110 001 63	110 001 61 110 001 62 110 001 63	- - -	- - -
	110 001 66 110 001 64 110 001 65	110 001 66 110 001 64 110 001 65	110 001 66 110 001 64 110 001 65	- - -	- - -
15	110 000 72 110 010 18	110 000 72 110 010 18	110 000 72 110 010 18	110 001 59 -	- -
16	110 006 03 110 006 04 110 006 48 110 013 06	110 006 03 110 006 04 110 006 48 110 013 06	110 006 03 110 006 04 110 006 48 110 013 06	110 006 03 110 006 04 110 006 48 110 013 06	- - - -
17	- -	- -	- -	- -	- -

① Not possible with YΔ start.

② J7 size 9 and 10

Special equipment

Monarch RL and RMS, sliding two stage

– weishaupt –

1	Pressure gauge with isolating valve	for RL burners for RMS burners		110 008 82 –	110 002 82 110 008 83
2	Pump	RL	E6 in lieu of J6 for ring main pressure > 2,0 bar	110 017 22	–
3	Vacuum gauge with isolating valve	for RL burners for RMS burners		110 005 69 –	110 017 00 110 017 00
4	Magnetic clutch for post purge	for RL burners for RMS burners		110 003 46 –	110 003 45 110 009 72
5	Magnetic clutch for post purge to relieve pressure	for RL burners for RMS burners		110 007 27 –	110 010 66 110 011 82
6	Potentiometer built onto servomotor		220 Ω 1000 Ω	110 002 86 110 003 03	110 002 86 110 003 03
			220/ 220 Ω 220/1000 Ω 1000/1000 Ω	110 011 12 110 011 13 110 011 14	110 011 12 110 011 13 110 011 14
7	Oil hoses 1300 in lieu of 1000 mm long heated (stainless steel)	for RL burners for RMS burners		110 000 72 –	110 001 59 110 010 18
8	Combustion head extensions	RL	100 mm 150 mm 200 mm 250 mm 300 mm	110 009 81 – 110 009 83 – –	– 110 010 59 – 110 010 61 –
		RMS	100 mm 150 mm 200 mm 250 mm 300 mm	– – – – –	– 110 010 90 – 110 010 91 –
9	Oil preheater MV9C (media) in addition to standard electric oil preheater Media connection fittings: see page 16, item 14			–	110 004 01
10	Oil preheater	WEV2.2 in lieu of EV2D WEV3. in lieu of EV2D		– –	110 011 33 –
		MV9C in lieu of EV2D MV9C in lieu of WEV3		– –	– –
11	Vertically firing burner with media preheaters only (MV 90h rotated because of condensate) Connection fittings: see M/MS burners			–	110 000 52
12	Burner controller	LAL 2.14 LAL 2.65 LAL 3.25 LOK 16.250		110 006 03 110 006 04 110 006 48 110 013 06	110 006 03 110 006 04 110 006 48 110 013 06
13	Price reductions Oil preheater EV2C in lieu of EV2D for RMS7			–	110 007 21

Burners supplied to TRD 411 and TRD 604

See special information (available on request).

No.	8 Order No.	8/2 Order No.	9 Order No.	10 Order No.	11 Order No.
1	110 002 82 110 008 83	110 002 82 110 008 83	110 002 82 110 008 83	110 002 82 110 008 83	110 002 82 110 008 83
-	-	-	-	-	-
3	110 017 00 110 017 00	110 017 00 110 017 00	110 017 00 110 017 00	110 017 00 110 017 00	110 017 00 110 017 00
4	110 009 71 110 009 72	110 009 71 110 009 72	110 009 74 110 009 75	110 009 74 110 009 75	110 009 74 110 009 75
5	110 003 95 110 015 99	110 003 95 110 015 99	110 007 39 110 005 66	110 007 39 110 005 66	110 007 39 110 005 67
6	110 002 86 110 003 03 110 011 12 110 011 13 110 011 14	110 002 86 110 003 03 110 011 12 110 011 13 110 011 14	110 002 86 110 003 03 110 011 12 110 011 13 110 011 14	110 002 86 110 003 03 110 011 12 110 011 13 110 011 14	110 002 86 110 003 03 110 011 12 110 011 13 110 011 14
7	110 001 59 110 010 18	110 001 59 110 010 18	110 001 59 110 010 18	110 001 59 110 010 18	- 180 000 63
8	- 110 002 42 - 110 002 44 - - 110 010 90 - 110 010 91 -	- 110 002 46 - 110 007 24 - - 110 010 92 - 110 010 93 -	- 110 006 76 - 110 002 87 - - 110 010 94 - 110 010 95 -	- 180 000 46 - 180 000 47 - - 180 000 84 - 180 000 85 -	- 180 000 24 - 180 000 01 - - 180 000 86 - 180 000 87 -
9	110 004 01	110 011 37	110 011 24	110 011 24	180 000 08
10	110 011 33 - - -	110 011 33 - 110 011 38 -	110 011 34 - 110 011 22 -	110 011 34 110 014 75 110 011 22 -	- - - 180 000 09
11	110 000 52	110 000 52	110 000 52	110 000 52	110 000 52
12	110 006 03 110 006 04 110 006 48 110 013 06	110 006 03 110 006 04 110 006 48 110 013 06	110 006 03 110 006 04 110 006 48 110 013 06	110 006 03 110 006 04 110 006 48 110 013 06	110 006 03 110 006 04 110 006 48 110 013 06
13	-	-	-	-	-

Weishaupt MV media preheaters

– weishaupt –

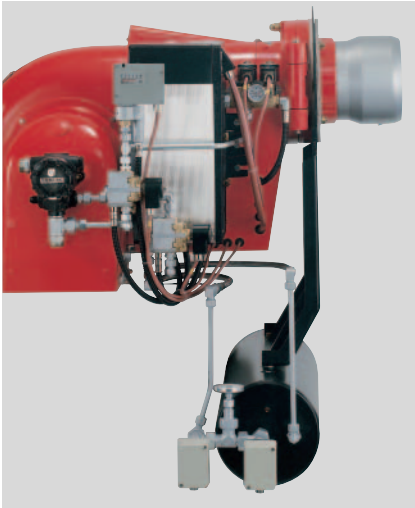

Type MS7Z with EV2D and MV9C

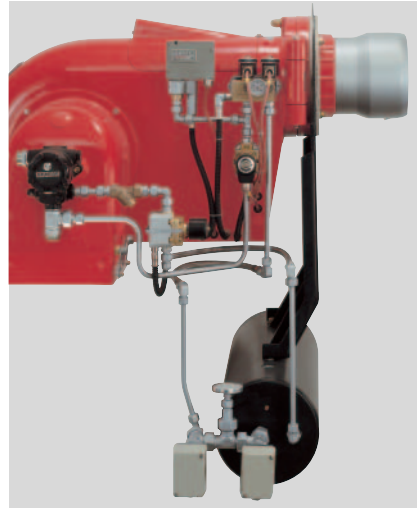

Type MS7Z with MV9C

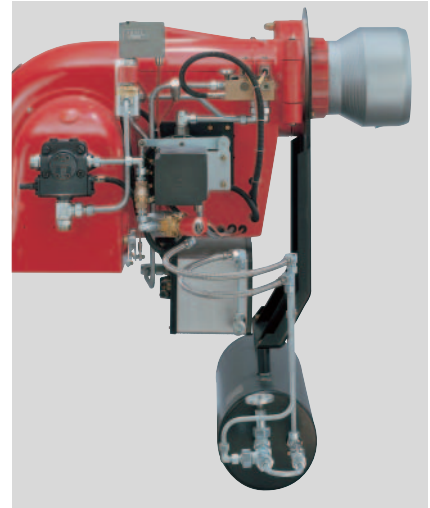

Type RMS8 with EV2D and MV9C

Oil connection parts for media preheaters with electric preheater

- 2 520 mm long hoses
- 1 Ball valve
- 1 precision thermometer
- 1 thermometer holder, unions and pipe connections

Oil connection parts for media preheaters without electric preheater

- 2 520 mm long hoses
- 1 temperature regulator with switch-over contact to release burner
- 1 temperature regulator and thermometer holder, unions and pipe connections

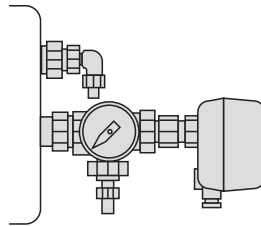
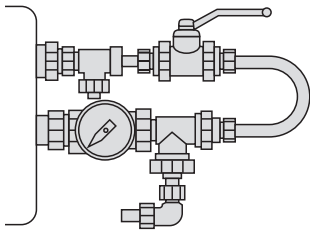

The units are high capacity forced circulation heat exchangers. Hot water, steam or thermal fluid can be used as a heating medium.

Media preheaters are used alone or in conjunction with an electric preheater.

If a medium of sufficient temperature is available, or if distillate oil is used, an electric preheater is not required. If the temperature of the medium is insufficient for preheating the fuel oil to atomising temperature the remainder of the heating process is carried out by an electric preheater.

The preheaters are equipped with all the necessary parts for the medium concerned.

There are Weishaupt media preheaters with numerous fittings for the different heating media.

Detailed information on the extent of delivery and arrangements is contained in a separate Weishaupt oil preheater brochure.

Weishaupt control panels and MCR technology

– weishaupt –



Weishaupt control panels for

- two stage burners
- three stage burners
- sliding two stage burners and modulating burners

The basic control panels contain all burner controls, that means all inbuilt switchgear necessary for the operation of a burner.

Description

Weishaupt control panels conform to applicable national/international standards.

Switching includes

- Power supply
- Burner control
- Fan control
- Start-up/regulation
- Door mounted switches
- Door mounted indicating lamps

Individual customer requirements can be met at any time.



Weishaupt control technology for

- Boiler installations
- Thermal process equipment
- Ships execution
- Building management systems

Together with its core business of burners and heating systems, Weishaupt are able to offer complex control technology up to BMS level with PLC and DDC systems.

From planning to handover, tailor made solutions are available from one supplier.

Dimensions

-weishaupt-

Monarch L and RL burners

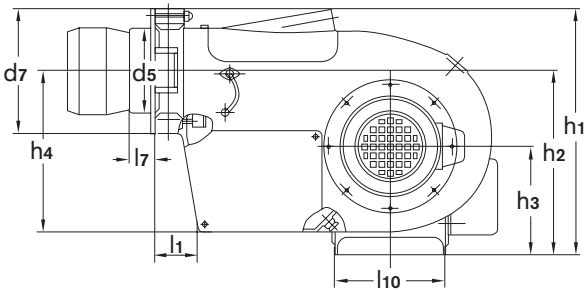

Monarch M /MS and RMS burners

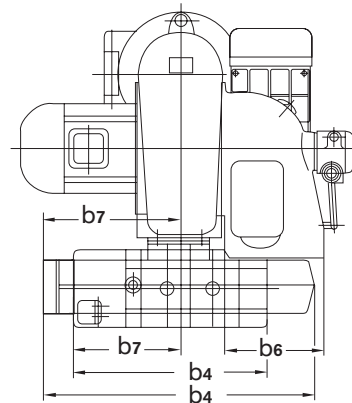
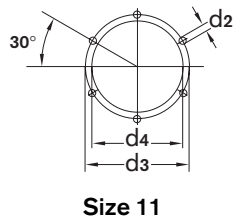
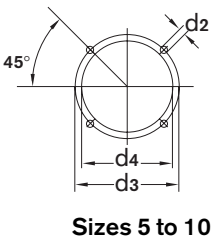
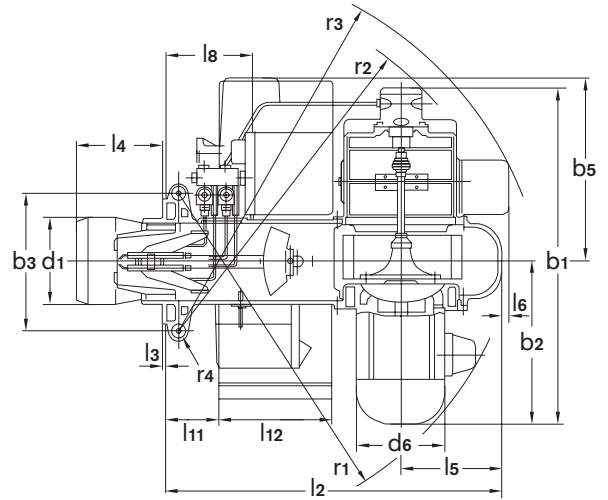
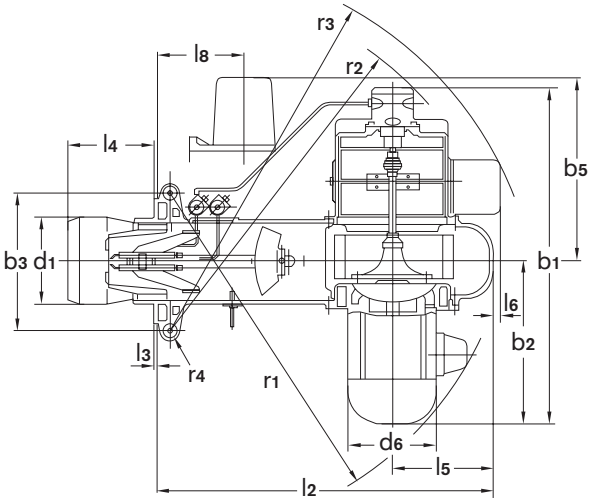
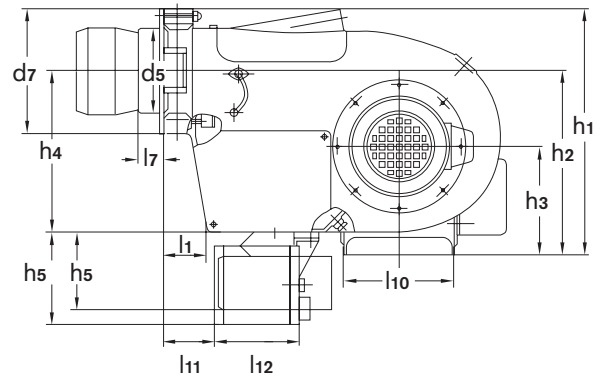

Burner size	5	7	8	8/2	9	10	11
l_1	100	100	100	102	112	112	117
l_2	686	766	766	767	945	945	950
l_3	8	8	8	8	8	8	8
l_4	M5/2a: 130 M5/1a: 145 -	M6/1a: 214 M7/1a: 224 -	M7/1a: 224 M8/1a: 234 -	M9/1a: 232 U2/1: 227 G7/2a: 256 -	M9/1a: 223 - -	M10/2: 273 - -	M11/1: 371 - -
l_5	200	224	224	224	300	300	300
l_6	47	28	28	28	15	15	-
l_7	34	57	57	80	92	68	195
l_8	239	285	285	287	310	310	315
l_{10}	239	255	255	255	390	390	390
b_1	644	763	784	784	884	884	911
b_2	297	369	388	388	439	439	462
b_3	270	310	310	310	440	440	440
b_5	394	414	414	414	436	436	436
b_6	200	231	231	231	230	230	230
h_1	494	556	556	590	672	672	707
h_2	373	415	415	415	482	482	482
h_3	220	245	245	245	260	260	260
h_4	363	366	366	366	482	482	482
d_1	M5/2a: 160 M5/1a: 180 -	M6/1a: 200 M7/1a: 220 -	M7/1a: 220 M8/1a: 240 -	M9/1a: 240 U2/1: 220 G7/2a: 265 -	M9/1a: 240 - -	M10/2: 265 - -	M11/1: 325 - -
d_2	M10	M10	M10	M12	M12	M12	M10
d_3	210	235	235	298	330	330	400
d_4	185	210	210	275	280	280	340
d_5	154	196	196	241	240	265	324
d_6	176	218	218	218	258	258	258
d_7	242	281	281	350	380	380	450
r_1	680	770	800	800	960	960	980
r_2	705	790	790	790	975	975	975
r_3	790	865	865	865	1090	1090	-
r_4	21	23	23	23	25	25	25
Additional dimensions for M /MS burners							
l_{11}	-	EV2C: 186 EV2D: 114 -	EV2D: 114 -	EV2D: 116 WEV2.2: 106 -	EV2D: 153 WEV2.2: 149 WEV3: 119 -	EV2D: 153 WEV2.2: 149 WEV3: 119 -	WEV3: 124 - -
l_{12}	-	EV2C: 126 EV2D: 198 -	EV2D: 198 -	EV2D: 198 WEV2.2: 254 -	EV2D: 198 WEV2.2: 254 WEV3: 314 -	EV2D: 198 WEV2.2: 254 WEV3: 314 -	WEV3: 314 - -
b_4	-	EV2C: 430 EV2D: 430 -	EV2D: 430 -	EV2D: 430 WEV2.2: 630 -	EV2D: 430 WEV2.2: 630 WEV3: 744 -	EV2D: 430 WEV2.2: 630 WEV3: 744 -	WEV3: 744 - -
b_7	-	EV2C: 235 EV2D: 235 -	EV2D: 235 -	EV2D: 235 WEV2.2: 327 -	EV2D: 235 WEV2.2: 327 WEV3: 384 -	EV2D: 235 WEV2.2: 327 WEV3: 384 -	WEV3: 384 - -
h_5	-	EV2C: 214 EV2D: 214 -	EV2D: 214 -	EV2D: 214 WEV2.2: 191 -	EV2D: 214 WEV2.2: 191 WEV3: 205 -	EV2D: 214 WEV2.2: 191 WEV3: 205 -	WEV3: 205 - -

* for special voltages

Product and customer service - the complete Weishaupt range

Max Weishaupt GmbH
D - 88475 Schwendi
Tel.: (07353) 830, Fax.: (07353) 83358
www.weishaupt.de

Print No. 8300202, March 2007
Printed in Germany. All rights reserved.

Neachells Lane, Willenhall, WV13 3RG
Tel: (01902) 609841, Fax: (01902) 633343

63 Carlton Place, Glasgow, G5 9TW
Tel: (0141) 420 2030, Fax: (0141) 420 2088
www.weishaupt.co.uk

— weishaupt —



Regular maintenance reduces heating costs and environmental pollution. Only a properly adjusted burner can save energy and be environmentally friendly. Behind each Weishaupt burner stands the whole Weishaupt customer service organisation. The outstanding efforts made in maintenance and service justify the enormous trust placed in Weishaupt's burners, for at Weishaupt product and customer service belong together.

Weishaupt customer service is there for you all year round. Whenever you need help, be it the supply of spare parts, technical advice or a site visit. We are there when you need us.