

Weishaupt gas burners
Sizes 30 to 70
Version LN / 1LN (Low NO_x)

–weishaupt–

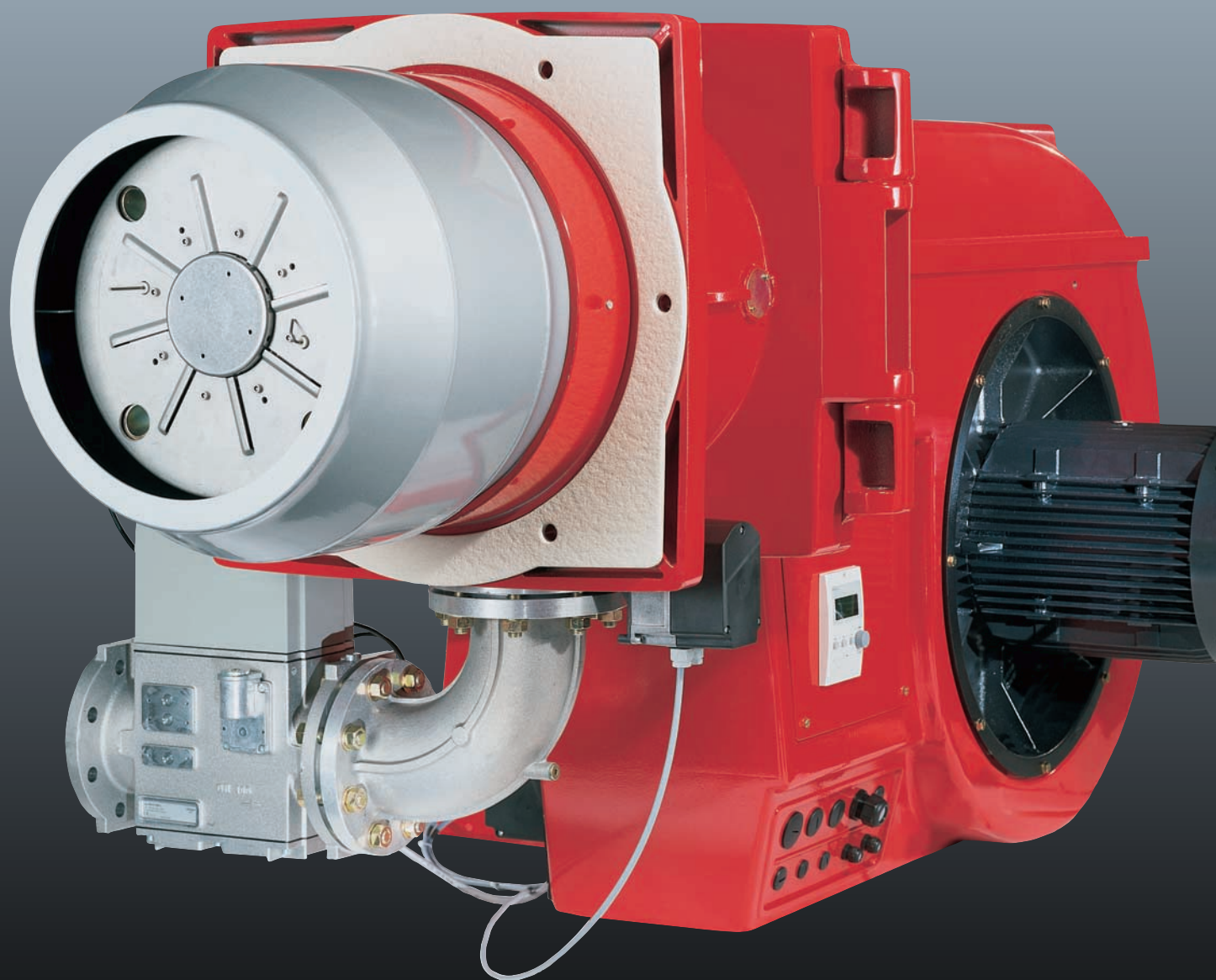

Description

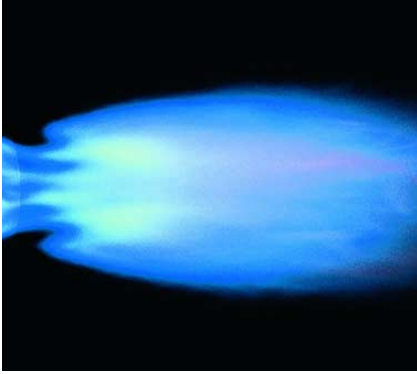

Typical Low NO_x flame pattern

Regulation

Dependent on fuel, burner size and requirements, the regulation of air and fuel is by:

- **Sliding two stage**

For sliding two stage control, partial and full load are set positions within the regulation range. The burner's firing rate slides between the two load points, depending on the heat demand. Thus there are no sudden large increases or decreases in the amount of fuel used.

- **Modulation**

Modulating burners operate at any point within the regulation range, depending on the heat demand.

Reduced capacity at start-up

The burners start at ignition load, set via the gas butterfly (LN) or an additional pilot line (1LN). In this way only a small amount of gas flows into the combustion chamber. After a short delay the burner moves to partial load operation.

Controlled shut downs from partial load

Controlled shut down of the burner always takes place from the partial load position, thus preventing impact on the gas main.

Valve trains

To comply with EN 676 burners must be equipped with two solenoid valves. Weishaupt gas and dual fuel burners are equipped with two Class A solenoid valves (DMV) as standard. The W-FM 100 combustion manager provides for valve proving when an additional gas

Weishaupt industrial burners, sizes 30 to 70, have been especially designed for industrial capacity ranges. The monobloc burners are noteworthy for their large capacity and operational ranges and numerous other interesting details:

- Compliance with the most stringent directives and emission limits
- Large capacity and operational ranges
- Stable fan reference line - good combustion behaviour
- Quiet operation
- Burner housing can be hinged open
- Easy to install, set and service
- Automatic air shut off on burner shut down

pressure switch is fitted. Other gas side accessories such as gas filters and gas pressure regulators, can be found in the List of Accessories

Digital combustion management

The W-FM 100 and W-FM 200* combustion managers ensure the simple and safe operation of combustion plant.

All important functions, such as fuel and air feed or flame monitoring are controlled with digital precision. The aim is the optimisation of operational functions, the maximisation of economy, and the minimisation of emissions. Thanks to digital combustion management such an optimisation is available today at limited cost. The outlay for installation and service is substantially lower than with conventional technologies.

For example, a separate control panel for the burner switchgear is no longer necessary. Furthermore, remote operation, diagnosis and monitoring of the plant can be realised. That makes things safer and simpler for the operator.

Applications

The burners can be used with heat exchangers such as hot water boilers, steam boilers, air heaters, and for certain process applications. As the burners are capable of overcoming high combustion chamber resistances, they are used primarily on modern high rated boilers.

Fuels

The gas burners have been tested for the following gases in accordance with DVGW Worksheet G 260/I:

LN version:

Natural Gas E (formerly designated Natural Gas H) and LL (formerly designated Natural Gas L).

1LN version:

Natural gases E + LL and liquid petroleum gas B/P

Installation sites

In standard execution (materials, construction, protection), the burners are suitable for use indoors at temperatures between -15°C and +40°C and with a maximum relative humidity of 80%.

Certification

The burners have been independently tested and comply with the following European standards and EC directives:

- EN 676
- Machinery Directive 98/37/EC
- Electromagnetic Compatibility Directive 89/336/EEC
- Low Voltage Directive 73/23/EEC
- Gas Appliance Directive 90/396/EEC
- Pressure Vessel Directive 97/23/EC

Outstanding service

Weishaupt maintains an extensive global sales and service network. Customer service is available every day around the clock. In-house training by Weishaupt ensures the high standard of their service engineers.

* Available early 2004

Variants

Digital combustion management (W-FM 100)	Electronic compound (RVW) with O ₂ trim	Mechanical compound
Digital combustion management (W-FM 100) with capacity regulation	Electronic compound (RVW) with speed control	
Digital combustion management (W-FM 100) with capacity regulation and speed control	Electronic compound (RVW) with O ₂ trim and speed control	
Digital combustion management (W-FM 200*) with capacity regulation O ₂ trim and speed control		

Standard
 Special execution

Capacity regulation

Sliding two stage (ZM)



Modulating (ZM)

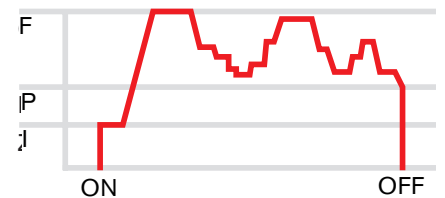

F = Full load
 P = Partial load
 I = Ignition load

Explanation of designation

G 40/1 – B, Vers. ZM-1LN

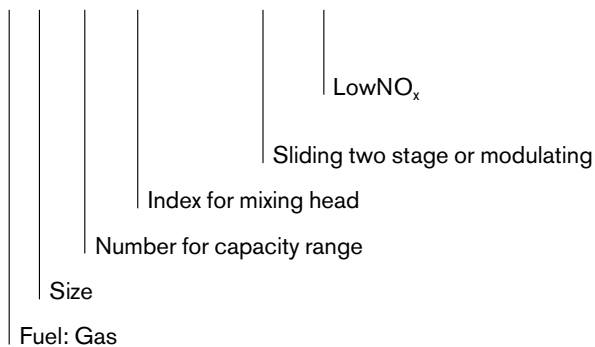

The advantages of digital combustion management



Control and Display Unit

Digital combustion management means optimal combustion figures, continually reproducible setting figures, and ease of use.

Weishaupt burners are equipped with electronic compound and digital combustion management since modern combustion technologies demand a precise, continually reproducible dosing of fuel and combustion air. Only in this way can optimal combustion figures be ensured over extended periods.

If required, the burners can also be equipped with O₂ trim* and speed control.

Error free operation via a clear text display.

Setting and control of the burner functions is achieved using a control and display unit with a clear text display. The CDU is linked to the combustion manager via a safety bus system and can be placed anywhere the user chooses within 100 m of the burner.

Flexible communication possibilities

The inbuilt interface enables all necessary information and functions to be relayed to a BMS system. If required, a modem enables a telephone connection to be installed for remote operation (e.g. oil/gas change-over, adjustment of setting values) and remote diagnosis.

Communication with external systems via Bus.

If data has to be exchanged between burners and other heating systems with PLC devices, Weishaupt E-Gate acts as a gateway and translates the eBus protocol into the standard Profibus DP protocol.

Integration with building management

For the control and management level, Weishaupt offers ProGraf NT - a software product that provides a real time solution to meet all requirements.

The price advantage of new technology

With improved technology and ease of use, combustion plant is becoming even more economical.

- No additional burner controls are required, since this effected by the combustion manager. Contactors and burner motor fuses are the only additional items required.
- Less installation work means fewer errors: the burners are tested as a complete unit at the factory.
- No additional costs for valve proving.
- If required, the W-FM 100 can be fitted with a capacity regulator and speed control module. No separate equipment is required. The capacity regulator and speed control module are included as standard with the W-FM 200.
- Commissioning and service work takes less time. The initial pre-setting of the burner is carried out at the factory. On site, only the site specific load points have to be determined.
- To facilitate O₂ trim, only an O₂ probe and O₂ module have to be installed and connected with the W-FM 200 via the internal safety bus.

* Available early 2004 in conjunction with the W-FM 200 combustion manager

-weishaupt-

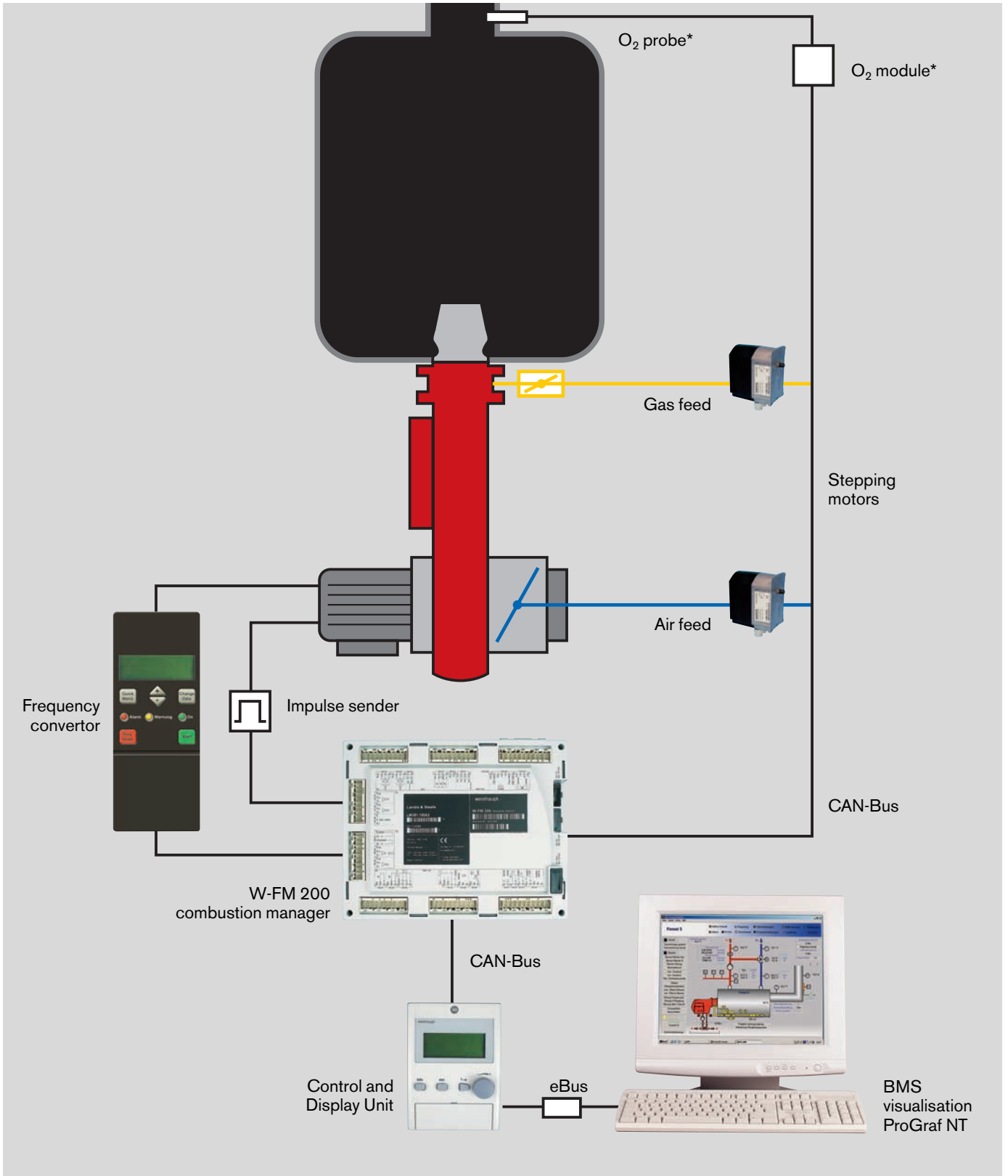

Example of O₂ trim and speed control with W-FM 200

Versions LN and 1LN in comparison

Main points in overview

LN version

The LN series has enjoyed success for many years. By being suitable only for Natural Gas (E and LL), a simplified construction can be employed and no additional gas pilot line is necessary.

- No pilot line
- Tested for Natural Gas E and LL
- Capacity range up to 8500 kW

1LN version

The need for Low NO_x operation of dual fuel burners when firing on gas led to the development of a new type of mixing head.

Due to the way the combustion air is distributed, which is different to LN burners, a separate gas pilot line is required. The capacity range is some 10 - 15% higher than the LN version, and the burner is also suitable and tested for use with Liquid Petroleum Gas.

- Pilot line required
- Tested for Natural Gas (E and LL) and LPG
- Capacity range up to 10000 kW

Capacity ranges of LN and 1LN versions

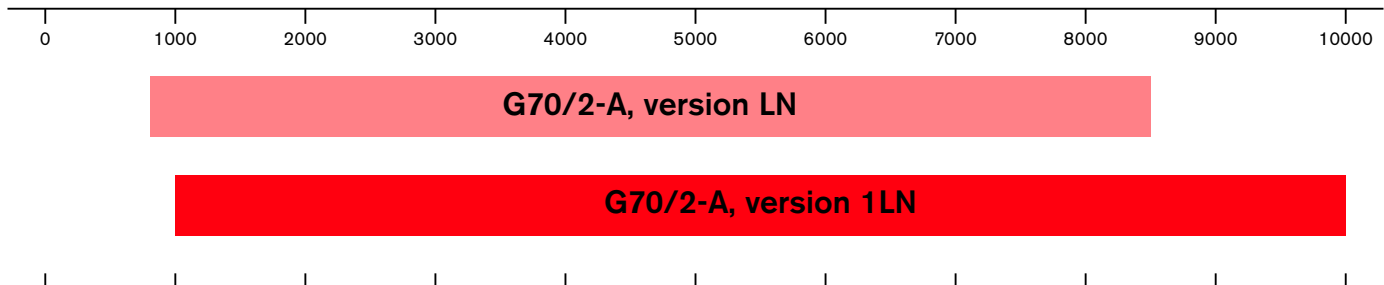

Capacity range of G70/2-A as an example

Emission figures for LN and 1LN versions

[mg/kWh] Example for Natural Gas operation

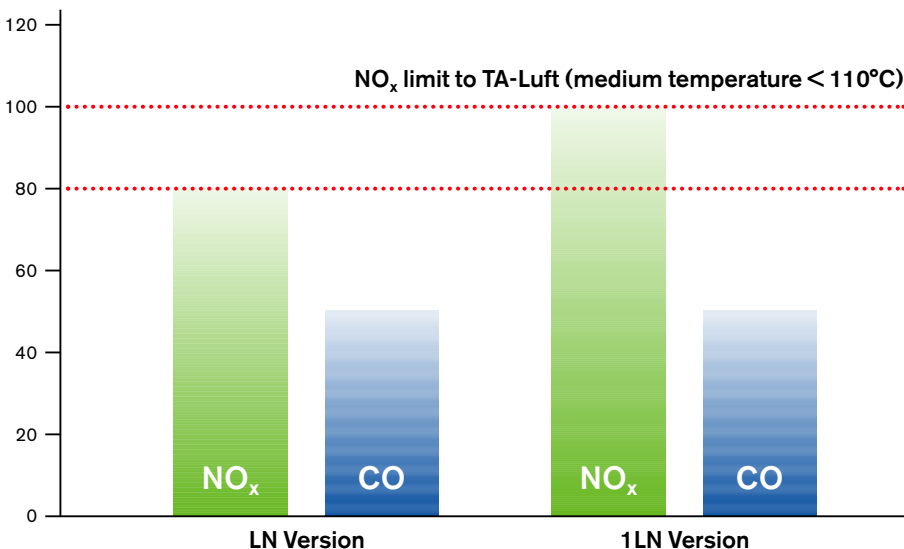

Notes and remarks

Differing good figures are produced depending on the geometry of the combustion chamber, volume load and firing system (3 pass or reverse flame).

When stating information relating to guaranteed values, certain conditions for measurement and evaluation must be taken into account, inter alia combustion chamber loading, test tolerances, temperature, pressure, humidity.

-weishaupt-

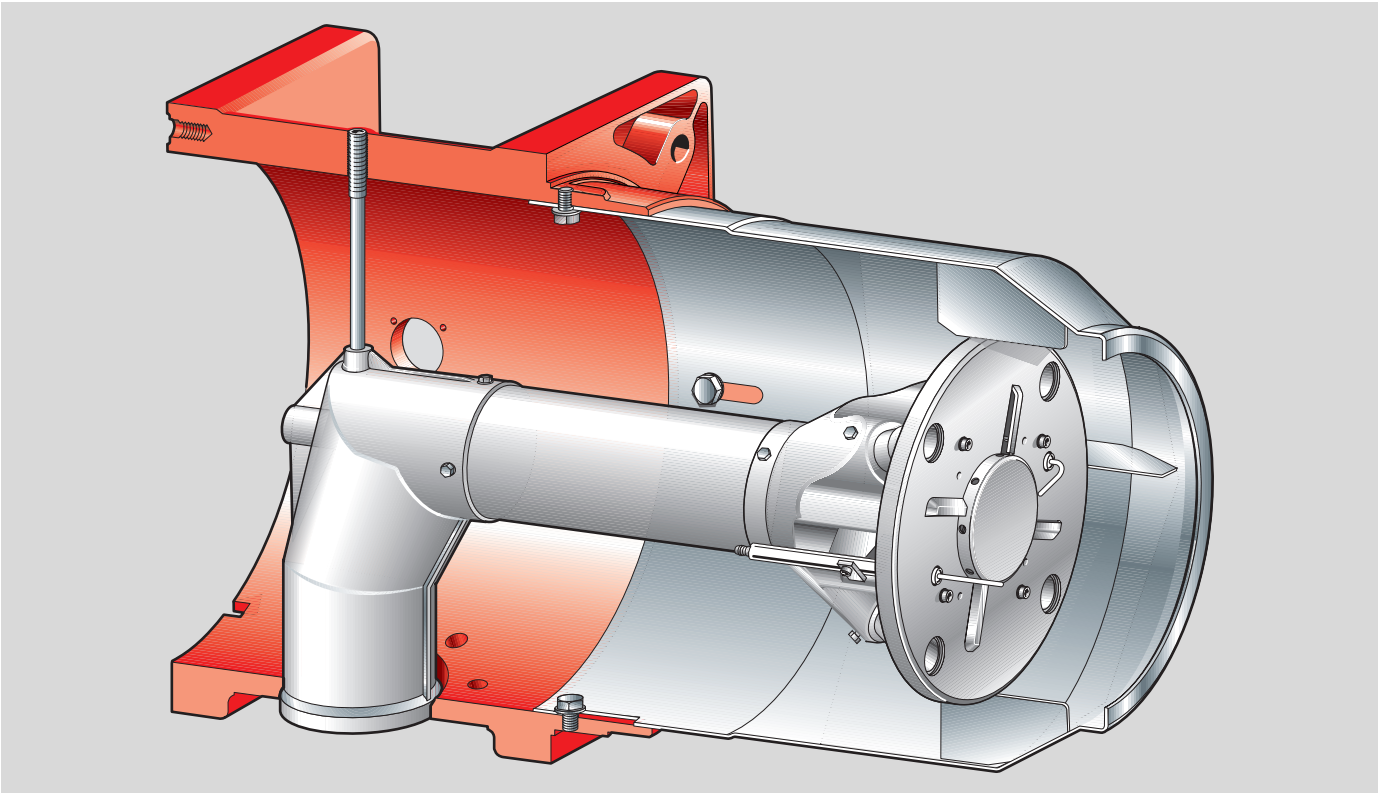

LN version mixing head

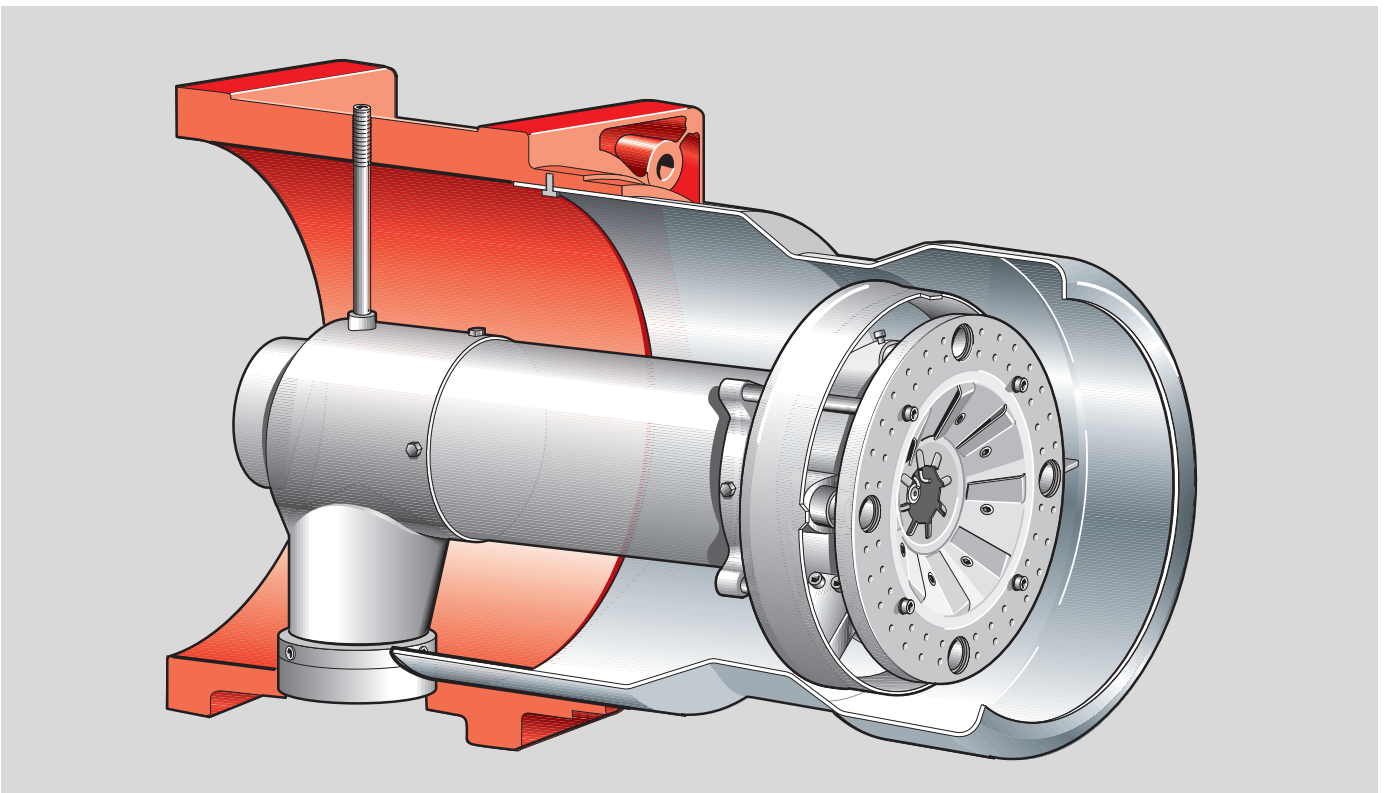

1LN version mixing head

LN version



G70/2-A ZM LN gas burner

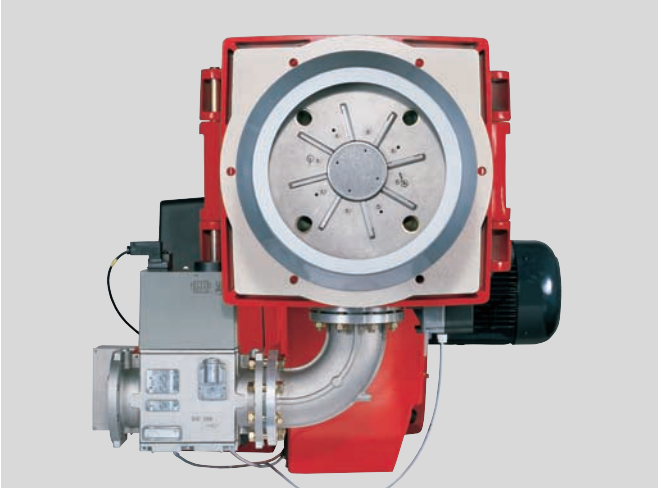

Burner complete with pre-mounted DMV and plug connections (additional cost)



Hinged flange for easy servicing

Gas burner selection

Types G30 and G40, LN version

– weishaupt –

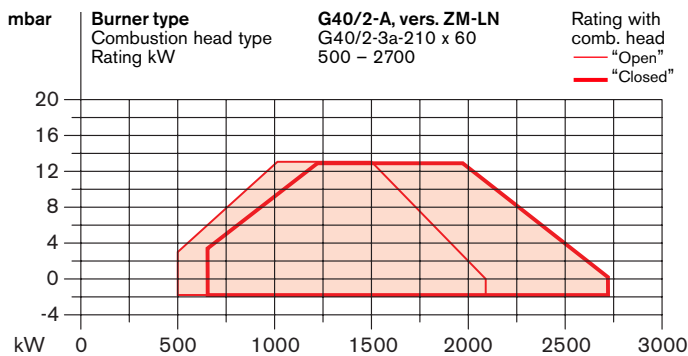
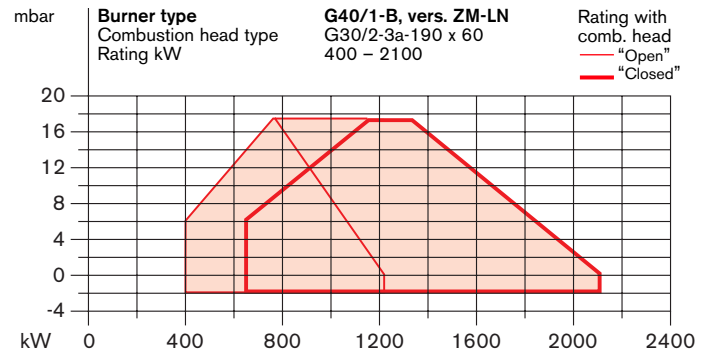
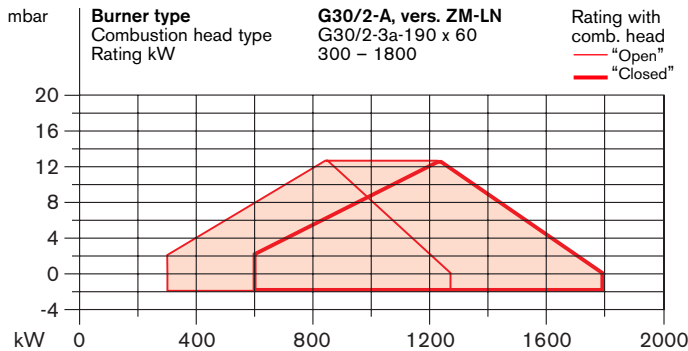

Burner type	Version	DIN-CERTCO No. Type test No.	Valve train DN / BSP	Order No.			
G30/2-A	ZM-LN	CE-0085AP 0528	R 1 1/2"	217 305 13			
			R 2"	217 305 15			
			DN 40	217 305 22			
			DN 50	217 305 32			
			DN 65	217 305 42			
			DN 80	217 305 52			
			DN 100	217 305 62			
			DN 125	217 305 72			
			G40/1-B	ZM-LN	CE-0085AQ 0720	R 1 1/2"	217 404 13
						R 2"	217 404 15
DN 40	217 404 22						
DN 50	217 404 32						
DN 65	217 404 42						
DN 80	217 404 52						
DN 100	217 404 62						
DN 125	217 404 72						
G40/2-A	ZM-LN	CE-0085AQ 0720				R 1 1/2"	217 405 18
						R 2"	217 405 19
			DN 40	217 405 23			
			DN 50	217 405 33			
			DN 65	217 405 43			
			DN 80	217 405 53			
			DN 100	217 405 63			
			DN 125	217 405 73			

The capacity ranges shown correspond to maximal values measured on idealised test flame tubes in accordance with EN 676.

The ratings given for sizes 30 to 50/2 are based on an air temperature of 20°C and an installation altitude of 500 m.

Voltages and frequencies:

As standard, the burners are suitable for three phase alternating current 400 V, 3 ~, 50 Hz. Other voltages and frequencies available on request at no extra cost.

Standard burner motor:

Isolation class F, IP 54 protection

Gas burner selection

Type G50, LN version

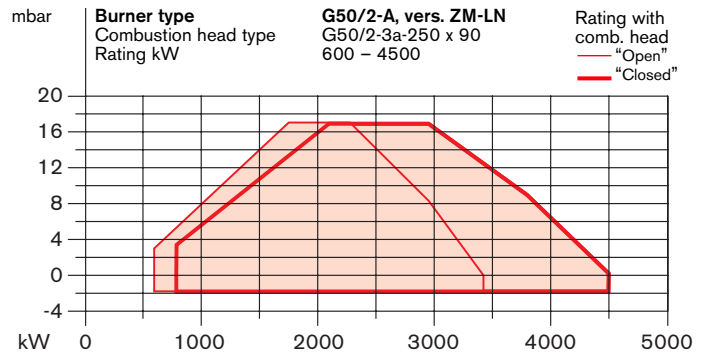
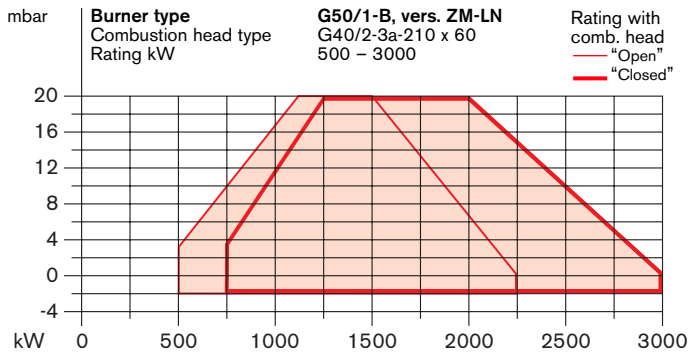

Burner type	Version	DIN-CERTCO No. Type test No.	Valve train DN / BSP	Order No.
G50/1-B	ZM-LN	CE-0085AQ 0721	R 1 1/2"	217 504 18
			R 2"	217 504 19
			DN 40	217 504 23
			DN 50	217 504 33
			DN 65	217 504 43
			DN 80	217 504 53
G50/2-A	ZM-LN	CE-0085AQ 0721	R 1 1/2"	217 505 18
			R 2"	217 505 19
			DN 40	217 505 23
			DN 50	217 505 33
			DN 65	217 505 43
			DN 80	217 505 53
			DN 100	217 505 63
DN 125	217 505 73			
			DN 150*	217 505 83

The capacity ranges shown correspond to maximal values measured on idealised test flame tubes in accordance with EN 676.

The ratings given for sizes 30 to 50/2 are based on an air temperature of 20°C and an installation altitude of 500 m.

Voltages and frequencies:

As standard, the burners are suitable for three phase alternating current 400 V, 3 ~, 50 Hz. Other voltages and frequencies available on request at no extra cost.

Standard burner motor:

Isolation class F, IP 54 protection

* DN 150 with two individual solenoid valves

Gas burner selection

Types G60 and G70, LN version

–weishaupt–

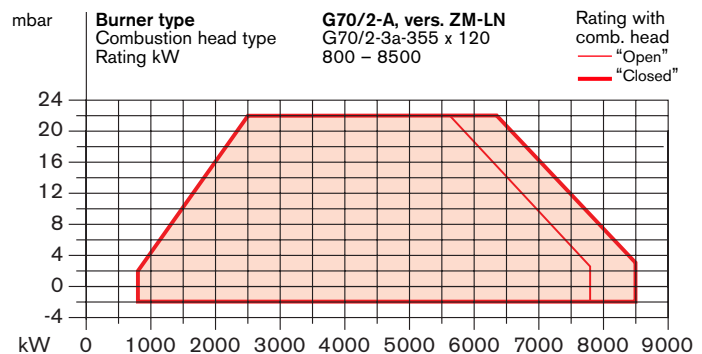
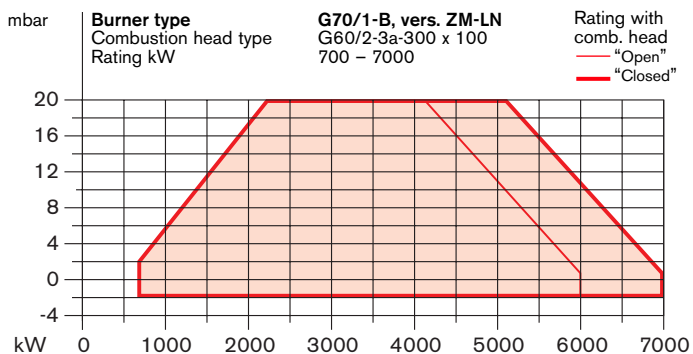
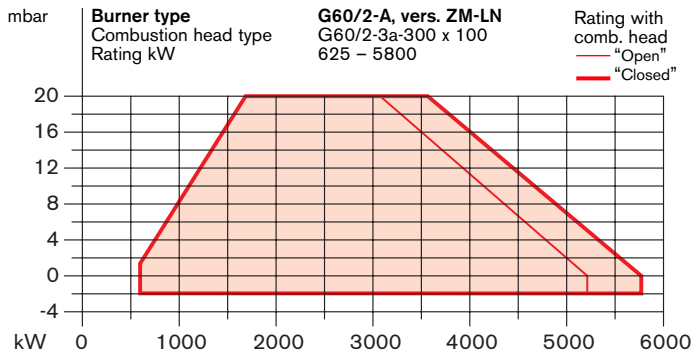

Burner type	Version	DIN-CERTCO No. Type test No.	Valve train DN / BSP	Order No.
G60/2-A	ZM-LN	CE-0085AQ 0722	DN 50	217 605 33
			DN 65	217 605 43
			DN 80	217 605 53
			DN 100	217 605 63
			DN 125	217 605 73
			DN 150*	217 605 83
G70/1-B	ZM-LN	CE-0085AQ 0723	DN 65	217 704 43
			DN 80	217 704 53
			DN 100	217 704 63
			DN 125	217 704 73
			DN 150*	217 704 83
G70/2-A	ZM-LN	CE-0085AQ 0723	DN 65	217 705 43
			DN 80	217 705 53
			DN 100	217 705 63
			DN 125	217 705 73
			DN 150*	217 705 83

The capacity ranges shown correspond to maximal values measured on idealised test flame tubes in accordance with EN 676.

The ratings given for sizes 60 and 70 are based on an installation altitude of 0 m in accordance with EN 676.

Depending on the altitude of the installation, a reduction in capacity of approximately 1% for every 100 m above sea level should be taken into account.

Voltages and frequencies:

As standard, the burners are suitable for three phase alternating current 400 V, 3 ~, 50 Hz. Other voltages and frequencies available on request at no extra cost.

Standard burner motor:

Isolation class F, IP 54 protection

* DN 150 with two individual solenoid valves

Valve train sizing with DMV valves

LN version

Type G30/2-A, version LN

Burner rating [kW]	Low pressure supply	High pressure supply
	(flow pressure in mbar before shut off valve $p_{e,max} = 300$ mbar)	(flow pressure in mbar before solenoid valve)
Nominal diameter of valve trains		
	40° 50° 65 80 100 125	40° 50° 65 80 100 125
Nom. diameter of gas butterfly valve		
	40 50 50 50 50 50	Nom. diam. of gas butterfly valve 40 50 50 50 50 50

Natural Gas E, $H_i = 37.26$ MJ/mn ³ (10.35 kWh/mn ³), d = 0.606
1000 52 34 24 20 19 18 27 24 19 16 16 15
1200 74 47 33 27 25 24 39 34 26 23 22 21
1300 84 52 36 29 27 26 43 37 28 25 23 23
1400 94 57 38 31 28 27 47 41 30 26 24 23
1500 105 63 41 32 29 27 52 44 32 27 25 24
1600 116 69 44 34 30 28 56 48 34 28 26 25
1700 129 75 47 36 31 29 61 52 36 30 27 26
1800 142 81 50 38 33 30 66 56 38 31 28 27

Natural Gas LL, $H_i = 31.79$ MJ/mn ³ (8.83 kWh/mn ³), d = 0.641
1000 73 46 32 27 24 23 38 33 26 22 21 21
1200 102 63 43 35 32 30 53 46 35 30 28 27
1300 116 71 47 37 34 32 59 50 37 32 30 29
1400 131 78 50 39 35 33 64 55 40 33 31 30
1500 147 86 54 42 37 34 71 60 42 35 32 31
1600 163 94 58 44 38 36 77 65 45 37 34 32
1700 181 103 62 46 40 37 84 70 48 39 35 33
1800 200 112 66 49 41 38 91 76 51 40 36 35

Type G40/1-B, version LN

Burner rating [kW]	Low pressure supply	High pressure supply
	(flow pressure in mbar before shut off valve $p_{e,max} = 300$ mbar)	(flow pressure in mbar before solenoid valve)
Nominal diameter of valve trains		
	40° 50° 65 80 100 125	40° 50° 65 80 100 125
Nom. diameter of gas butterfly valve		
	40 50 50 50 50 50	Nom. diam. of gas butterfly valve 40 50 50 50 50 50

Natural Gas E, $H_i = 37.26$ MJ/mn ³ (10.35 kWh/mn ³), d = 0.606
1000 52 34 24 20 19 18 27 24 19 16 16 15
1200 74 47 33 27 25 24 39 34 26 23 22 21
1400 94 57 38 31 28 27 47 41 30 26 24 23
1600 116 69 44 34 30 28 56 48 34 28 26 25
1800 142 81 50 38 33 30 66 56 38 31 28 27
1900 155 88 53 39 34 32 72 60 40 33 30 28
2000 170 95 56 41 35 33 77 64 43 34 31 29
2100 185 103 60 43 37 34 83 69 45 35 32 30

Natural Gas LL, $H_i = 31.79$ MJ/mn ³ (8.83 kWh/mn ³), d = 0.641
1000 73 46 32 27 24 23 38 33 26 22 21 21
1200 102 63 43 35 32 30 53 46 35 30 28 27
1400 131 78 50 39 35 33 64 55 40 33 31 30
1600 163 94 58 44 38 36 77 65 45 37 34 32
1800 200 112 66 49 41 38 91 76 51 40 36 35
1900 220 122 71 51 43 40 99 82 54 42 38 36
2000 241 132 75 54 45 41 107 88 57 44 39 37
2100 262 143 80 56 47 42 116 95 60 46 41 38

Type G40/2-A, version LN

Burner rating [kW]	Low pressure supply	High pressure supply
	(flow pressure in mbar before shut off valve $p_{e,max} = 300$ mbar)	(flow pressure in mbar before solenoid valve)
Nominal diameter of valve trains		
	40° 50° 65 80 100 125	40° 50° 65 80 100 125
Nom. diameter of gas butterfly valve		
	40 50 65 65 65 65	Nom. diam. of gas butterfly valve 40 50 65 65 65 65

Natural Gas E, $H_i = 37.26$ MJ/mn ³ (10.35 kWh/mn ³), d = 0.606
1600 112 65 38 29 25 23 52 44 29 23 21 20
1800 142 81 48 36 31 29 66 56 37 29 27 26
2000 170 95 54 39 33 30 77 64 41 32 28 27
2200 201 111 61 43 35 32 89 73 45 34 30 28
2400 235 127 68 46 37 34 102 83 49 37 32 30
2600 271 145 75 50 40 35 116 94 54 39 34 31
2800 - 164 83 54 42 37 131 106 59 42 36 33

Natural Gas LL, $H_i = 31.79$ MJ/mn ³ (8.83 kWh/mn ³), d = 0.641
1600 161 92 54 40 34 32 75 63 41 33 30 28
1800 201 113 65 47 40 37 92 77 49 39 35 33
2000 241 133 73 51 42 38 108 89 54 42 37 34
2200 285 154 82 56 45 40 124 101 60 44 39 36
2400 - 178 91 60 47 42 - 115 66 47 41 37
2600 - 203 102 65 50 44 - 130 72 51 43 39
2800 - 231 113 71 53 46 - - 79 54 45 40

Type G50/1-B, version LN

Burner rating [kW]	Low pressure supply	High pressure supply
	(flow pressure in mbar before shut off valve $p_{e,max} = 300$ mbar)	(flow pressure in mbar before solenoid valve)
Nominal diameter of valve trains		
	40° 50° 65 80 100 125	40° 50° 65 80 100 125
Nom. diameter of gas butterfly valve		
	40 50 65 65 65 65	Nom. diam. of gas butterfly valve 40 50 65 65 65 65

Natural Gas E, $H_i = 37.26$ MJ/mn ³ (10.35 kWh/mn ³), d = 0.606
1800 142 81 48 36 31 29 66 56 37 29 27 26
2000 170 95 54 39 33 30 77 64 41 32 28 27
2200 201 111 61 43 35 32 89 73 45 34 30 28
2400 235 127 68 46 37 34 102 83 49 37 32 30
2600 271 145 75 50 40 35 116 94 54 39 34 31
2800 - 164 83 54 42 37 131 106 59 42 36 33
3000 - 185 92 59 45 39 - 118 65 45 38 34

Natural Gas LL, $H_i = 31.79$ MJ/mn ³ (8.83 kWh/mn ³), d = 0.641
1800 201 113 65 47 40 37 92 77 49 39 35 33
2000 241 133 73 51 42 38 108 89 54 42 37 34
2200 285 154 82 56 45 40 124 101 60 44 39 36
2400 - 178 91 60 47 42 - 115 66 47 41 37
2600 - 203 102 65 50 44 - 130 72 51 43 39
2800 - 231 113 71 53 46 - - 79 54 45 40
3000 - 260 125 76 56 48 - - 86 58 47 42

The combustion chamber pressure in mbar must be added to the minimum gas pressure required.

For low pressure supplies, pressure regulating devices with safety membrane in accordance with EN 88 are used. The maximum permissible supply pressure before the shut off valve is 300 mbar.

For high pressure supplies, high pressure regulating devices in accordance with EN 3380 can be selected from the brochure 'Pressure regulating units with safety assemblies for Weishaupt gas and dual fuel burners'. This details high gas pressure sets suitable for supply pressures of up to 4 bar.

See burner plate for maximum supply pressure.

* The figures given for size DN 40 also apply to 1 1/2" and those for DN 50 to 2" valve trains.

Valve train sizing with DMV valves

LN version

-weishaupt-

Type G50/2-A, version LN

Burner rating [kW]	Low pressure supply (flow pressure in mbar before shut off valve $p_{e,max} = 300$ mbar) Nominal diameter of valve trains 40* 50* 65 80 100 125 150 Nom. diameter of gas butterfly valve 50 50 65 80 80 80 80	High pressure supply (flow pressure in mbar before solenoid valve) Nominal diameter of valve trains 40* 50* 65 80 100 125 150 Nom. diam. of gas butterfly valve 50 50 65 80 80 80 80
--------------------	---	--

Natural Gas E, $H_i = 37.26 \text{ MJ/m}^3$ (10.35 kWh/m ³) d = 0.606						
2700	273	151	76	48	37	29
3000	-	184	91	57	43	34
3300	-	-	108	67	50	43
3600	-	-	127	77	57	49
3900	-	-	146	88	64	55
4200	-	-	167	99	72	60
4500	-	-	188	111	80	67

Natural Gas LL, $H_i = 31.79 \text{ MJ/m}^3$ (8.83 kWh/m ³) d = 0.641						
2700	-	215	105	65	48	38
3000	-	-	129	79	59	46
3300	-	-	155	94	70	55
3600	-	-	182	110	81	63
3900	-	-	-	126	92	72
4200	-	-	-	144	104	87
4500	-	-	-	162	116	97

Type G70/1-B, version LN

Burner rating [kW]	Low pressure supply (flow pressure in mbar before shut off valve $p_{e,max} = 300$ mbar) Nominal diameter of valve trains 65 80 100 125 150 Nom. diameter of gas butterfly valve 65 80 100 100 100	High pressure supply (flow pressure in mbar before solenoid valve) Nominal diameter of valve trains 65 80 100 125 150 Nom. diam. of gas butterfly valve 65 80 100 100 100
--------------------	--	---

Natural Gas E, $H_i = 37.26 \text{ MJ/m}^3$ (10.35 kWh/m ³) d = 0.606						
4200	150	82	54	43	38	
4600	179	98	64	50	44	
5000	209	114	74	58	51	
5400	-	131	85	66	58	
5800	-	149	96	74	65	
6200	-	168	107	82	72	
6600	-	188	119	90	79	
7000	-	-	131	99	86	

Natural Gas LL, $H_i = 31.79 \text{ MJ/m}^3$ (8.83 kWh/m ³) d = 0.641						
4200	211	113	72	55	48	
4600	-	135	86	66	58	
5000	-	158	101	77	67	
5400	-	183	116	88	77	
5800	-	-	131	100	86	
6200	-	-	147	111	95	
6600	-	-	162	121	104	
7000	-	-	178	132	113	

The combustion chamber pressure in mbar must be added to the minimum gas pressure required.

For low pressure supplies, pressure regulating devices with safety membrane in accordance with EN 88 are used. The maximum permissible supply pressure before the shut off valve is 300 mbar.

Type G60/2-A, version LN

Burner rating [kW]	Low pressure supply (flow pressure in mbar before shut off valve $p_{e,max} = 300$ mbar) Nominal diameter of valve trains 50* 65 80 100 125 150 Nom. diameter of gas butterfly valve 65 65 80 100 100 100	High pressure supply (flow pressure in mbar before solenoid valve) Nominal diameter of valve trains 50* 65 80 100 125 150 Nom. diam. of gas butterfly valve 65 65 80 100 100 100
--------------------	---	--

Natural Gas E, $H_i = 37.26 \text{ MJ/m}^3$ (10.35 kWh/m ³) d = 0.606						
4000	-	138	77	51	41	37
4400	-	165	91	61	48	43
4600	-	180	99	65	52	46
4800	-	195	107	70	55	49
5000	-	210	115	75	59	52
5200	-	-	122	80	62	55
5400	-	-	130	84	65	57
5600	-	-	138	89	68	60

Natural Gas LL, $H_i = 31.79 \text{ MJ/m}^3$ (8.83 kWh/m ³) d = 0.641						
4000	-	192	103	67	51	45
4400	-	-	124	80	61	54
4600	-	-	135	87	67	58
4800	-	-	147	93	72	63
5000	-	-	158	100	77	67
5200	-	-	169	107	81	70
5400	-	-	180	113	85	74
5600	-	-	192	119	90	77

Type G70/2-A, version LN

Burner rating [kW]	Low pressure supply (flow pressure in mbar before shut off valve $p_{e,max} = 300$ mbar) Nominal diameter of valve trains 65 80 100 125 150 Nom. diameter of gas butterfly valve 65 80 100 100 100	High pressure supply (flow pressure in mbar before solenoid valve) Nominal diameter of valve trains 65 80 100 125 150 Nom. diam. of gas butterfly valve 65 80 100 100 100
--------------------	--	---

Natural Gas E, $H_i = 37.26 \text{ MJ/m}^3$ (10.35 kWh/m ³) d = 0.606						
5600	-	119	70	49	41	
6000	-	136	79	56	46	
6400	-	154	89	62	51	
6800	-	172	99	69	57	
7200	-	192	110	76	62	
7600	-	212	121	83	68	
8000	-	-	130	89	71	
8500	-	-	142	95	76	

Natural Gas LL, $H_i = 31.79 \text{ MJ/m}^3$ (8.83 kWh/m ³) d = 0.641						
5600	-	166	94	64	52	
6000	-	190	107	73	59	
6400	-	215	121	82	66	
6800	-	-	135	91	73	
7200	-	-	150	101	80	
7600	-	-	165	110	88	
8000	-	-	181	121	95	
8500	-	-	129	101		

For high pressure supplies, high pressure regulating devices in accordance with EN 3380 can be selected from the brochure 'Pressure regulating units with safety assemblies for Weishaupt gas and dual fuel burners'. This details high gas pressure sets suitable for supply pressures of up to 4 bar.

See burner plate for maximum supply pressure.

* The figures given for size DN 40 also apply to 1 1/2" and those for DN 50 to 2" valve trains.

1LN version

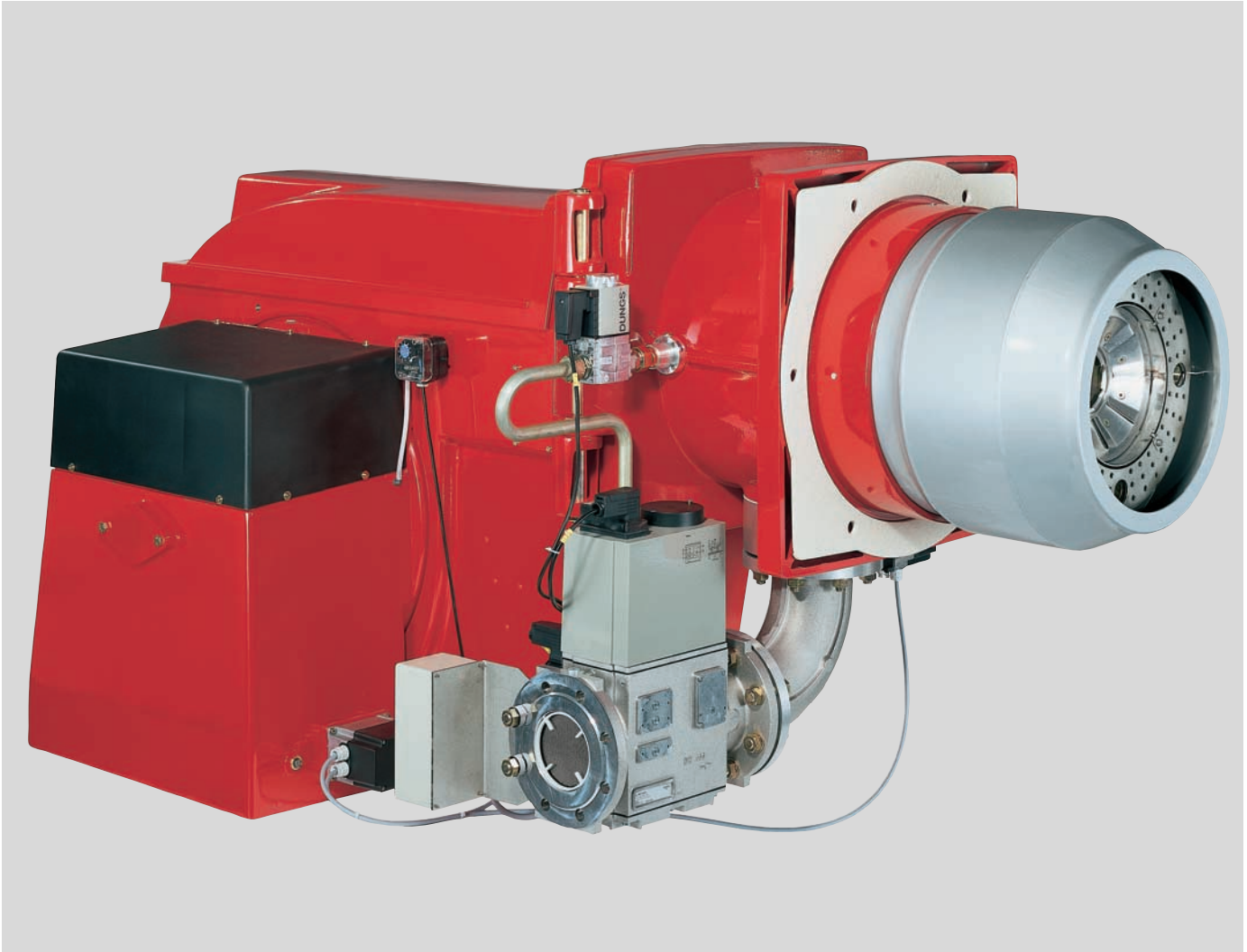

G70/2-A ZM 1LN gas burner, complete with pre-mounted DMV and plug connections (additional cost)



Burner with inbuilt Control and Display Unit

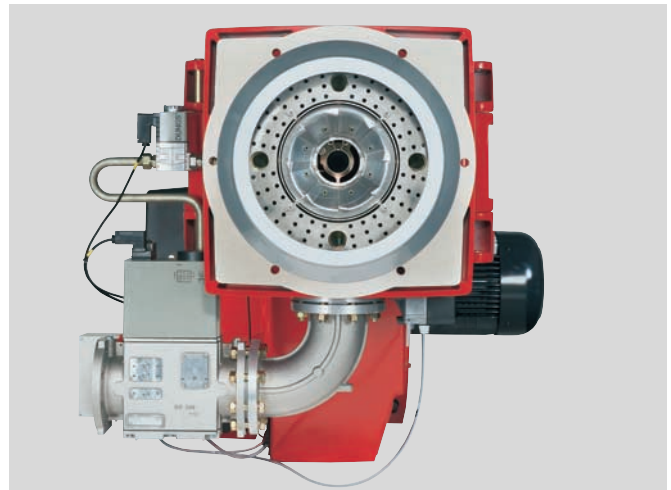

Front view

Gas burner selection

Types G30 and G40, 1LN version

– weishaupt –

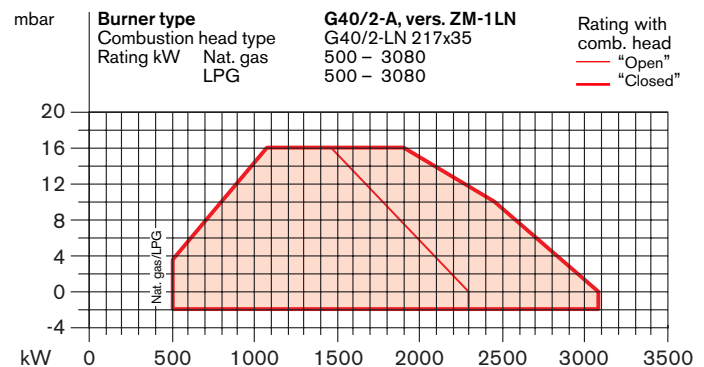
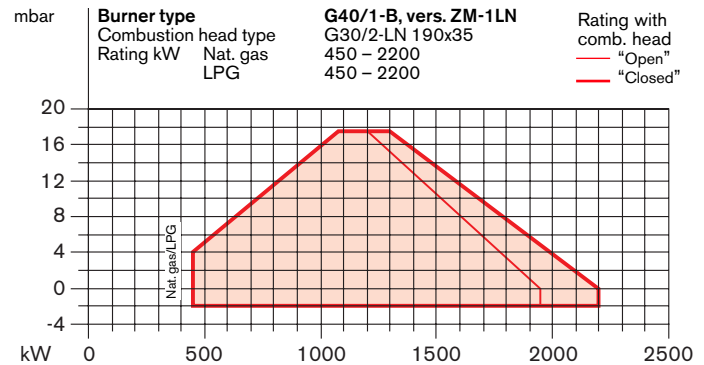
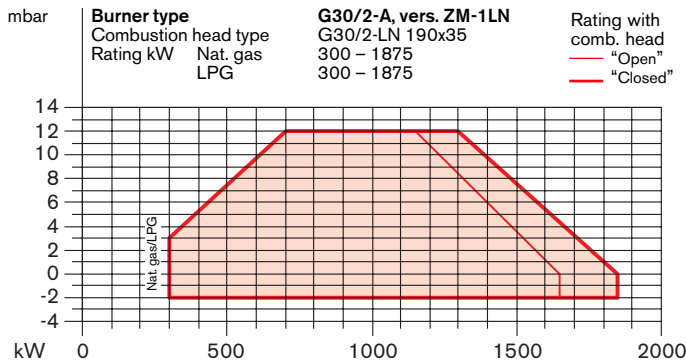

Burner type	Version	DIN-CERTCO No. Type test No.	Valve train DN / BSP	Order No.
G30/2-A	ZM-1LN	CE-0085AP 0528	R 11/2	217 305 16
			R 2	217 305 17
			DN 40	217 305 25
			DN 50	217 305 35
			DN 65	217 305 45
			DN 80	217 305 55
			DN 100	217 305 65
DN 125	217 305 75			
G40/1-B	ZM-1LN	CE-0085AQ 0720	R 11/2	217 404 16
			R 2	217 404 17
			DN 40	217 404 25
			DN 50	217 404 35
			DN 65	217 404 45
			DN 80	217 404 55
			DN 100	217 404 65
DN 125	217 404 75			
G40/2-A	ZM-1LN	CE-0085AQ 0720	R 11/2	217 405 16
			R 2	217 405 17
			DN 40	217 405 25
			DN 50	217 405 35
			DN 65	217 405 45
			DN 80	217 405 55
			DN 100	217 405 65
DN 125	217 405 75			

The capacity ranges shown correspond to maximal values measured on idealised test flame tubes in accordance with EN 676.

The ratings given are based on an installation altitude of 0 m in accordance with EN 676.

Depending on the altitude of the installation, a reduction in capacity of approximately 1% for every 100 m above sea level should be taken into account.

Voltages and frequencies:

As standard, the burners are suitable for three phase alternating current 400 V, 3 ~, 50 Hz. Other voltages and frequencies available on request at no extra cost.

Standard burner motor:

Isolation class F, IP 54 protection

Gas burner selection

Types G50 and G70, 1LN version

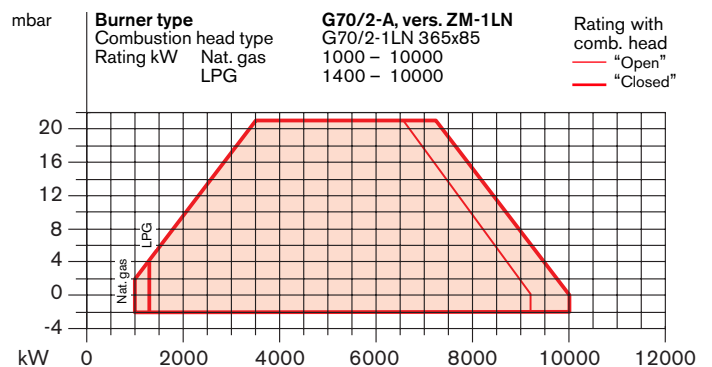
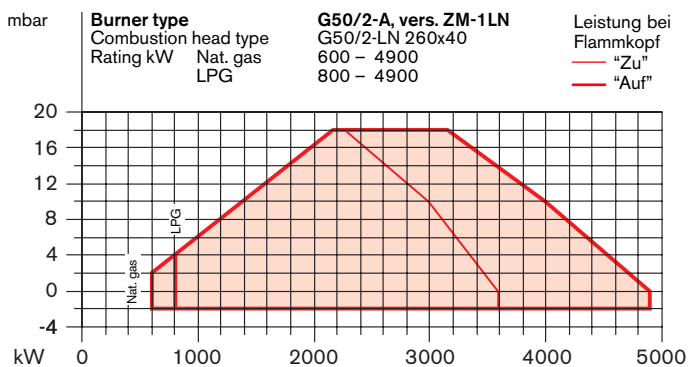
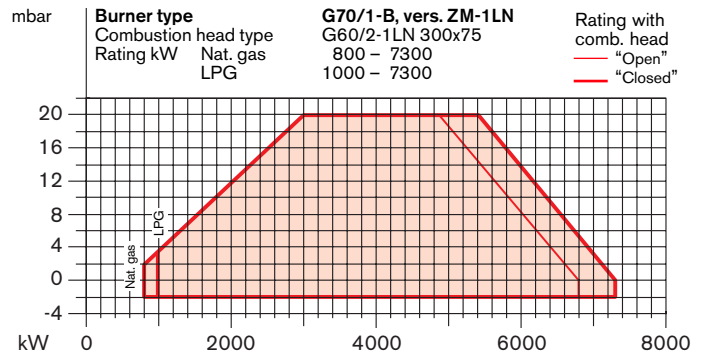
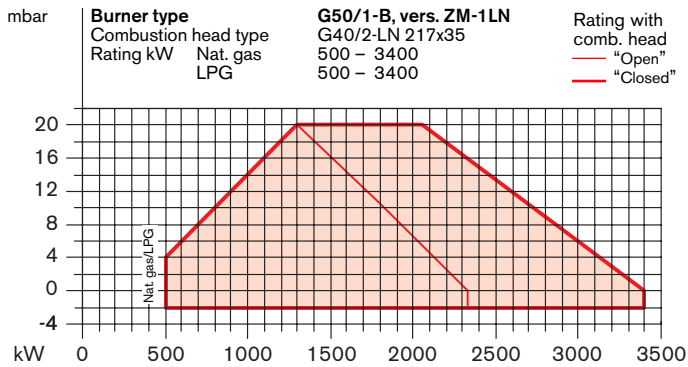

Burner type	Version	DIN-CERTCO No. Type test No.	Valve train DN / BSP	Order No.
G50/1-B	ZM-1LN	CE-0085AQ 0721	R 11/2	217 504 16
			R 2	217 504 17
			DN 40	217 504 25
			DN 50	217 504 35
			DN 65	217 504 45
			DN 80	217 504 55
G50/2-A	ZM-1LN	CE-0085AQ 0721	R 11/2	217 505 16
			R 2	217 505 17
			DN 40	217 505 25
			DN 50	217 505 35
			DN 65	217 505 45
			DN 80	217 505 55
G70/1-B	ZM-1LN	CE-0085AQ 0723	DN 65	217 704 45
			DN 80	217 704 55
			DN 100	217 704 65
			DN 125	217 704 75
			DN 150*	217 704 85
			DN 150*	217 704 85
G70/2-A	ZM-1LN	CE-0085AQ 0723	DN 65	217 705 45
			DN 80	217 705 55
			DN 100	217 705 65
			DN 125	217 705 75
			DN 150*	217 705 85
			DN 150*	217 705 85

The capacity ranges shown correspond to maximal values measured on idealised test flame tubes in accordance with EN 676.

The ratings given are based on an installation altitude of 0 m in accordance with EN 676.

Depending on the altitude of the installation, a reduction in capacity of approximately 1% for every 100 m above sea level should be taken into account.

Voltages and frequencies:

As standard, the burners are suitable for three phase alternating current 400 V, 3 ~, 50 Hz. Other voltages and frequencies available on request at no extra cost.

Standard burner motor:

Isolation class F, IP 54 protection

* DN 150 with two individual solenoid valves

Valve train sizing with DMV valves

1 LN version

-weishaupt-

Type G30/2-A and G40/1-B, version 1LN

Burner rating [kW]	Low pressure supply (flow pressure in mbar before shut off valve $p_{e,max}$ = 300 mbar)	High pressure supply (flow pressure in mbar before solenoid valve)
	Nominal diameter of valve trains 40* 50* 65 80 100 125	Nominal diameter of valve trains 40* 50* 65 80 100 125
	Nom. diameter of gas butterfly valve 40 50 50 50 50 50	Nom. diam. of gas butterfly valve 40 50 50 50 50 50

Natural Gas E, $H_i = 37.26 \text{ MJ/m}^3$ (10.35 kWh/m 3) $d = 0.606$

1000	49 30 21 17 15 15	24 21 15 13 12 12
1300	80 48 32 26 23 22	39 34 25 21 20 19
1400	92 55 36 29 26 24	45 39 28 24 22 21
1500	104 62 40 32 28 27	51 44 32 27 25 24
1600	118 70 45 35 31 30	57 49 35 30 28 27
1800	146 86 54 42 37 35	71 60 43 36 33 32
2000	178 104 65 50 44 41	86 73 51 42 39 37
2200	213 123 76 58 50 47	102 86 60 49 45 43

Natural Gas LL, $H_i = 31.79 \text{ MJ/m}^3$ (8.83 kWh/m 3) $d = 0.641$

1000	67 40 26 20 18 17	32 27 19 16 15 14
1300	110 64 40 31 28 26	52 44 31 26 24 23
1400	127 74 46 35 31 29	60 51 36 29 27 26
1500	145 84 52 40 35 32	69 58 40 33 30 29
1600	164 94 58 44 38 36	77 65 45 37 34 32
1800	205 117 71 53 46 43	96 81 56 45 41 39
2000	251 142 85 64 55 51	117 98 67 54 49 47
2200	170 101 75 64 59	140 117 79 64 58 55

LPG B/P, $H_i = 93.20 \text{ MJ/m}^3$ (25.89 kWh/m 3) $d = 1.555$

1000	25 17 13 11 11 11	13 12 9 8 8 8
1300	40 27 20 17 16 16	21 19 15 14 13 13
1400	45 30 22 19 18 18	25 22 18 16 15 15
1500	51 34 25 22 20 20	28 25 20 18 17 17
1600	58 38 28 24 23 22	32 28 23 20 20 19
1800	72 47 34 29 27 26	40 35 28 25 24 24
2000	88 57 41 35 32 31	48 43 34 30 29 28
2200	105 68 48 41 38 37	57 51 40 36 34 34

Type G50/2-A version 1LN

Burner rating [kW]	Low pressure supply (flow pressure in mbar before shut off valve $p_{e,max}$ = 300 mbar)	High pressure supply (flow pressure in mbar before solenoid valve)
	Nominal diameter of valve trains 40* 50* 65 80 100 125 150	Nominal diameter of valve trains 40* 50* 65 80 100 125 150
	Nom. diameter of gas butterfly valve 50 50 65 80 80 80 80	Nom. diam. of gas butterfly valve 50 50 65 80 80 80 80

Natural Gas E, $H_i = 37.26 \text{ MJ/m}^3$ (10.35 kWh/m 3) $d = 0.606$

2500	235 130 65 41 32 28 26	92 82 46 31 26 24 23
2800	295 163 83 52 40 35 33	116 105 58 40 34 31 30
3100	199 100 64 49 42 40	128 71 49 41 37 36
3400	119 74 57 49 46	84 58 48 44 42
3800	144 89 67 57 53	102 69 57 51 49
4200	171 103 76 65 60	120 79 65 58 55
4600	199 117 85 71 65	138 89 72 63 60
4900	128 91 75 69	96 76 67 63

LPG B/P, $H_i = 93.20 \text{ MJ/m}^3$ (25.89 kWh/m 3) $d = 1.555$

2500	183 89 55 41 35 32	129 116 62 41 34 30 29
2800	112 69 51 44 41	78 52 43 38 37
3100	137 83 62 53 49	96 64 52 47 45
3400	162 98 72 61 57	113 75 61 54 52
3800	199 118 86 72 67	138 90 73 64 62
4200	139 100 83 76	105 84 74 71
4600	161 114 94 85	121 96 83 79
4900	178 124 101 92	133 104 90 85

LPG B/P, $H_i = 93.20 \text{ MJ/m}^3$ (25.89 kWh/m 3) $d = 1.555$

2500	108 65 38 28 24 23 22	48 44 29 23 21 20 19
2800	141 87 54 41 36 34 34	66 61 42 35 32 31 31
3100	176 109 69 53 47 45 44	84 78 55 46 43 41 41
3400	211 132 83 64 57 54 53	102 95 67 56 52 50 50
3800	261 161 100 78 68 65 63	125 116 81 68 63 61 60
4200	191 116 89 78 73 71	137 94 77 71 69 68
4600	131 98 85 79 77	105 85 78 74 73
4900	142 104 89 82 80	112 89 81 77 76

Type G40/2-A and Type G50/1-B, version 1LN

Burner rating [kW]	Low pressure supply (flow pressure in mbar before shut off valve $p_{e,max}$ = 300 mbar)	High pressure supply (flow pressure in mbar before solenoid valve)
	Nominal diameter of valve trains 40* 50* 65 80 100 125	Nominal diameter of valve trains 40* 50* 65 80 100 125
	Nom. diameter of gas butterfly valve 40 50 65 65 65 65	Nom. diam. of gas butterfly valve 40 50 65 65 65 65

Natural Gas E, $H_i = 37.26 \text{ MJ/m}^3$ (10.35 kWh/m 3) $d = 0.606$

1600	107 59 33 23 19 17	47 38 23 17 15 14
1800	132 72 38 26 21 19	57 46 27 20 17 16
2000	161 87 45 30 24 22	69 55 32 23 20 18
2200	193 103 53 35 28 24	82 66 37 27 23 21
2400	229 121 62 40 32 28	96 77 43 31 26 24
2600	267 141 72 46 36 32	113 90 50 36 30 27
3000	187 94 60 47 41	120 67 47 39 36
3400	239 120 77 59 52	86 60 51 46

Natural Gas LL, $H_i = 31.79 \text{ MJ/m}^3$ (8.83 kWh/m 3) $d = 0.641$

1600	151 82 44 30 24 22	65 53 31 23 20 18
1800	189 101 52 35 27 24	80 65 37 26 23 21
2000	230 122 62 40 31 28	97 78 43 31 26 24
2200	276 145 73 47 36 31	116 92 51 35 30 27
2400	171 85 54 41 35	136 109 59 41 34 31
2600	199 98 61 46 40	126 68 47 39 35
3000	262 127 79 58 50	89 60 49 44
3400	161 99 73 62	112 75 62 55

LPG B/P, $H_i = 93.20 \text{ MJ/m}^3$ (25.89 kWh/m 3) $d = 1.555$

1600	53 33 23 19 17 16	27 23 17 15 14 14
1800	64 40 26 21 19 18	32 28 20 17 16 15
2000	77 47 30 24 21 20	38 32 23 19 18 17
2200	92 55 34 27 24 23	45 38 26 22 20 19
2400	108 64 39 31 27 25	52 44 30 25 23 22
2600	126 74 45 35 31 29	61 51 35 29 27 26
3000	166 97 59 45 39 37	80 68 46 38 35 34
3400	212 124 75 57 50 47	103 87 59 49 45 43

The combustion chamber pressure in mbar must be added to the minimum gas pressure required.

For low pressure supplies, pressure regulating devices with safety membrane in accordance with EN 88 are used. The maximum permissible supply pressure before the shut off valve is 300 mbar.

For high pressure supplies, high pressure regulating devices in accordance with EN 3380 can be selected from the brochure 'Pressure regulating units with safety assemblies for Weishaupt gas and dual fuel burners'. This details high gas pressure sets suitable for supply pressures of up to 4 bar.

See burner plate for maximum supply pressure.

* The figures given for size DN 40 also apply to 1 1/2" and those for DN 50 to 2" valve trains.

Valve train sizing with DMV valves

1LN version

Type G70/1-B, version 1LN

Burner rating [kW]	Low pressure supply (flow pressure in mbar before shut off valve p _{e,max} = 300 mbar)					High pressure supply (flow pressure in mbar before solenoid valve)				
	Nominal diameter of valve trains					Nominal diameter of valve trains				
	65	80	100	125	150	65	80	100	125	150
	Nom. diameter of gas butterfly valve					Nom. diam. of gas butterfly valve				
	65	80	100	100	100	65	80	100	100	100

Natural Gas E, H_i = 37.26 MJ/mn³ (10.35 kWh/mn³), d = 0.606

4600	180	99	66	52	46	119	71	52	44	41
5000	210	114	75	58	52	139	81	59	49	46
5400	-	131	85	66	58	160	93	68	56	52
5800	-	150	96	74	65	183	106	77	63	59
6200	-	170	109	84	74	-	120	87	72	66
6600	-	192	123	95	83	-	136	98	81	75
7000	-	-	138	106	93	-	153	111	91	84
7300	-	-	150	116	101	-	167	121	99	92

Natural Gas LL, H_i = 31.79 MJ/mn³ (8.83 kWh/mn³), d = 0.641

4600	-	137	88	68	60	167	96	70	57	53
5000	-	158	101	77	67	194	111	79	65	60
5400	-	182	115	87	76	-	128	91	74	68
5800	-	-	131	99	86	-	146	103	84	77
6200	-	-	148	112	97	-	166	117	95	88
6600	-	-	168	127	109	-	188	133	108	99
7000	-	-	-	142	123	-	-	150	122	112
7300	-	-	-	155	134	-	-	164	133	122

LPG B/P, H_i = 93.20 MJ/mn³ (25.89 kWh/mn³), d = 1.555

4600	103	70	56	51	48	77	57	50	46	45
5000	119	80	64	57	54	89	65	56	52	51
5400	137	91	72	64	61	101	74	64	59	57
5800	156	104	82	73	69	116	84	72	67	65
6200	178	117	92	82	78	132	95	82	75	73
6600	-	132	104	92	87	149	108	92	85	83
7000	-	148	116	103	98	167	121	104	96	93
7300	-	161	127	112	106	182	132	113	104	101

The combustion chamber pressure in mbar must be added to the minimum gas pressure required.

For low pressure supplies, pressure regulating devices with safety membrane in accordance with EN 88 are used. The maximum permissible supply pressure before the shut off valve is 300 mbar.

Type G70/2-A version 1LN

Burner rating [kW]	Low pressure supply (flow pressure in mbar before shut off valve p _{e,max} = 300 mbar)					High pressure supply (flow pressure in mbar before solenoid valve)				
	Nominal diameter of valve trains					Nominal diameter of valve trains				
	65	80	100	125	150	65	80	100	125	150
	Nom. diameter of gas butterfly valve					Nom. diam. of gas butterfly valve				
	65	80	100	100	100	65	80	100	100	100

Natural Gas E, H_i = 37.26 MJ/mn³ (10.35 kWh/mn³), d = 0.606

6000	-	134	77	53	43	170	87	56	41	37
7000	-	180	102	71	57	-	118	75	55	49
7500	-	206	117	80	65	-	135	86	63	56
8000	-	-	132	91	73	-	153	97	72	63
8500	-	-	149	102	82	-	172	109	81	71
9000	-	-	-	114	91	-	-	123	90	79
9500	-	-	-	126	101	-	-	136	100	88
10000	-	-	-	139	112	-	-	151	111	97

Natural Gas LL, H_i = 31.79 MJ/mn³ (8.83 kWh/mn³), d = 0.641

6000	-	188	105	71	56	-	121	76	55	48
7000	-	-	142	96	76	-	166	104	75	66
7500	-	-	163	110	87	-	190	119	86	75
8000	-	-	185	124	99	-	-	135	98	85
8500	-	-	-	140	111	-	-	152	110	96
9000	-	-	-	156	123	-	-	170	123	107
9500	-	-	-	-	137	-	-	189	136	119
10000	-	-	-	-	151	-	-	-	150	131

LPG B/P, H_i = 93.20 MJ/mn³ (25.89 kWh/mn³), d = 1.555

6000	127	71	47	38	33	84	50	37	31	29
7000	172	95	63	50	44	114	68	50	42	40
7500	197	109	72	57	50	131	78	58	49	45
8000	-	123	81	64	57	148	88	65	55	51
8500	-	138	91	72	63	167	99	74	62	58
9000	-	154	102	80	70	187	111	82	69	64
9500	-	171	112	88	78	-	123	91	76	71
10000	-	-	124	97	86	-	136	100	84	79

For high pressure supplies, high pressure regulating devices in accordance with EN 3380 can be selected from the brochure 'Pressure regulating units with safety assemblies for Weishaupt gas and dual fuel burners'. This details high gas pressure sets suitable for supply pressures of up to 4 bar.

See burner plate for maximum supply pressure.

* The figures given for size DN 40 also apply to 1 1/2" and those for DN 50 to 2" valve trains.

Scope of delivery

Valve train layout

– weishaupt –

Description	G30		G40		G50		G60	G70	
	LN	1LN	LN	1LN	LN	1LN	LN	LN	1LN
Burner housing, hinged flange, housing cover, Weishaupt burner motor, air regulation housing, fan wheel, combustion head, ignition unit, ignition cable, ignition electrodes, combustion manager with control unit, flame sensor, flange gasket, limit switch on hinged flange, fixing screws	●	●	●	●	●	●	●	●	●
W-FM 100 combustion manager	●	●	●	●	●	●	●	●	●
Gas double solenoid valve (DMV), Class A (DN 150 valve train includes two single solenoid valves type MVD 5150)	●	●	●	●	●	●	●	●	●
1LN version: additional pilot line solenoid valve		●		●		●			●
Gas butterfly valve	●	●	●	●	●	●	●	●	●
Valve connection piece	●	●	●	●	●	●	●	●	●
Air pressure switch	●	●	●	●	●	●	●	●	●
Gas pressure switch	●	●	●	●	●	●	●	●	●
Settable fixed regulating sleeve in the mixing head		●		●		●			
Settable fixed flame tube in the mixing head	●		●		●		●	●	●
Servomotor for fuel/air compound regulation via W-FM 100									
Servomotor for air damper	●	●	●	●	●	●	●	●	●
Servomotor for gas butterfly	●	●	●	●	●	●	●	●	●

In accordance with EN 676, gas filters and governors form part of the burner supply (see Weishaupt Accessories List)
 Burner execution complies with TRD 606, 24 h/72 h see technical brochure, Print No. 863.

LN version:

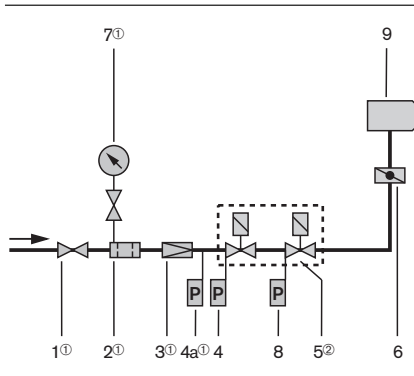

Legend

- 1 Isolating cock ①
- 2 Gas filter ①
- 3 Governor (LP) ①
- 4 Low gas pressure switch
- 4a High gas pressure switch (for TRD) ①
- 5 Double solenoid valve (DMV) ②
- 5a Pilot line solenoid valve
- 6 Gas butterfly valve
- 7 Gas pressure gauge and cock ①
- 8 Gas pressure switch (valve proving)
- 9 Burner

- ① Not included in burner price
- ② Single solenoid valves for DN 150

1LN version:

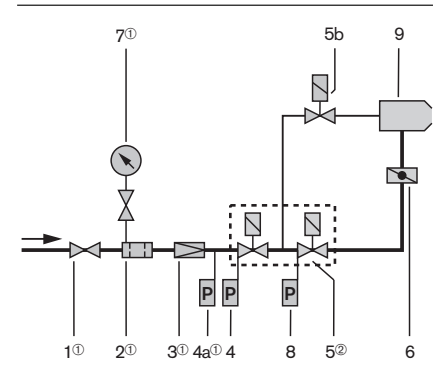

Installation example

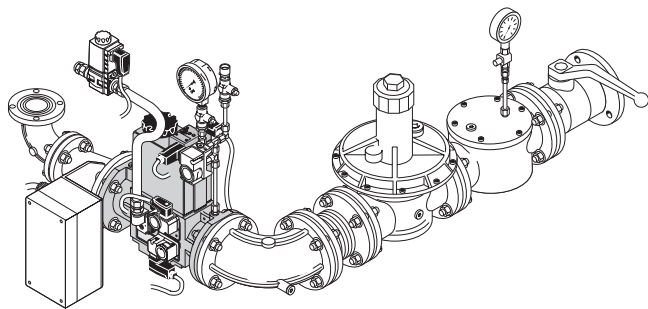

Low pressure supply: flanged valve train with DMV valves

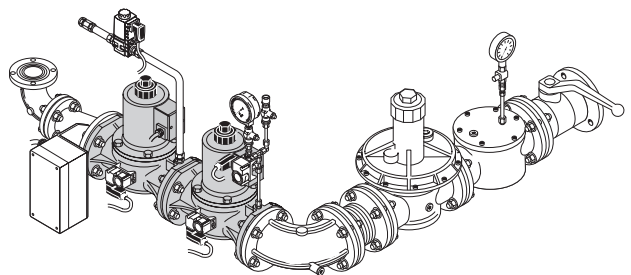

Single solenoid valves

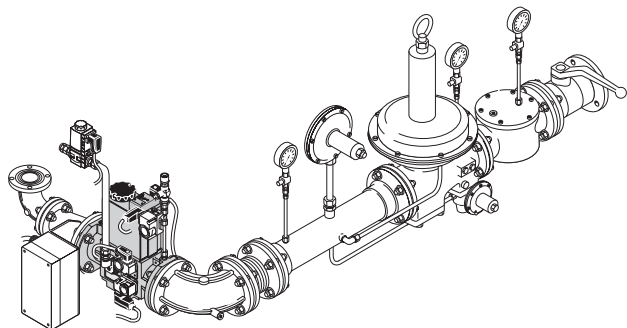

High pressure supply: flanged valve train with DMV valves

The installation example shows a basic valve train, i.e. DMV solenoid valves and additional gas valve train components.

Layout of the valve train

On boilers with hinged doors, the valve train must be mounted on the opposite side to the boiler door hinges. The pilot line solenoid valve can be fitted to either side.

Compensator

To enable a tension free mounting of the valve train, it is recommended that a compensator is also fitted.

Break points in the valve train

Break points in the gas line should be provided to enable the door of the heat exchanger to be swung open. The main gas line is best separated at the compensator.

Support of the valve train

The valve train should be properly supported in accordance with the site conditions. See the Weishaupt Accessories List for various valve train support components.

Gas meter

A gas meter must be installed to measure gas consumption during commissioning.

Special equipment

Technical data

– weishaupt –

Special equipment versions LN and 1LN	Size 30	Size 40	Size 50	Size 60 [®]	Size 70	
Vertically firing burner version	standard	standard	standard	standard	standard	
Air intake flange for connection of an air duct	280 003 47	280 001 68	280 000 92	280 000 38	280 000 13	
Combustion head extension Version LN	by 150 mm, types ../1-B	290 003 22	290 006 30	–	290 007 70	
	by 300 mm, types ../1-B	–	290 003 23	290 006 31	–	
	by 150 mm, types ../2-A	290 003 22	290 006 30	290 007 08	290 007 70	290 007 88
	by 300 mm, types ../2-A	290 003 23	290 006 31	290 007 09	290 007 71	290 007 89
Combustion head extension Version 1LN	by 150 mm, types ../1-B	–	*	*	–	290 010 76
	by 300 mm, types ../1-B	–	*	*	–	290 010 77
	by 150 mm, types ../2-A	290 011 10	*	290 009 38	–	290 010 95
	by 300 mm, types ../2-A	–	*	*	–	*
Capacity regulator for W-FM 100	290 010 60	290 010 60	290 010 60	290 010 60	290 010 60	
Burner controller						
Mechanical compound with LFL in lieu of W-FM 100 -price reduction-	290 011 02	290 011 02	290 011 02	290 011 02	290 011 02	
Mechanical compound with LGK in lieu of W-FM 100 -price reduction-	290 011 09	290 011 09	290 011 09	290 011 09	290 011 09	
Solenoid valve for air pressure switch test for continuous run fan or post purge	290 004 29	290 004 29	290 000 31	290 000 31	290 000 31	

Note: Additional price on request for DMV pre-mounted on burner with plug connections.

* Additional price on request

Technical data		G30/2-A	G40/1-B	G40/2-A	G50/1-B
Burner motor 400 V, 3 ~, 50 Hz	Type	D112/110-2	D112/140-2a	D112/140-2a	D132/120-2
Nominal capacity	kW	4.5	5.5	7	9
Nominal load at 400 V	A	9.5	11	13.4	18
Motor prefuse (ΥΔ start)	A	25	25	25	35
Speed (50 Hz)	rpm	2900	2900	2900	2850
Fan wheel	colour / Ø	blue / 268 x 100	blue / 295 x 100	blue / 295 x 100	blue / 345 x 100
Ignition unit	Type	W-ZG 02/2	W-ZG 02/2	W-ZG 02/2	W-ZG 02/2
Combustion manager	Type	W-FM100	W-FM100	W-FM100	W-FM100
Servomotor	Type	SQM 45	SQM 45	SQM 45	SQM 45
Weight					
Gas burner (without valve train)	kg (approx.)	120	130	130	195

Technical data		G50/2-A	G60/2-A [®]	G70/1-B	G70/2-A
Burner motor 400 V, 3 ~, 50 Hz	Type	D132/170-2	D132/170-2	② ③	D160/215-2
Nominal capacity	kW	13.5	13.5	18 14	21
Nominal load at 400 V	A	25	25	36.5 27	39
Motor prefuse (ΥΔ start)	A	50	50	63 50	63
Speed (50 Hz)	rpm	2900	2900	2900 2900	2900
Fan wheel	colour / Ø	blue / 345 x 100	blue / 515 x 120	blue / 590 x 160	blue / 590 x 160
Ignition unit	Type	W-ZG 02/2	W-ZG 02/2	W-ZG 02/2	W-ZG 02/2
Combustion manager	Type	W-FM100	W-FM100	W-FM100	W-FM100
Servomotor	Type	SQM 45	SQM 45	SQM 45	SQM 45
Weight (without valve train)	kg (approx.)	200	290	390	390

① LN version only

② For 1LN version with D160/215-2B motor

③ For LN version with D160/150-2 motor

Dimensions LN version

Sizes 30 to 50

Sizes 60 to 70

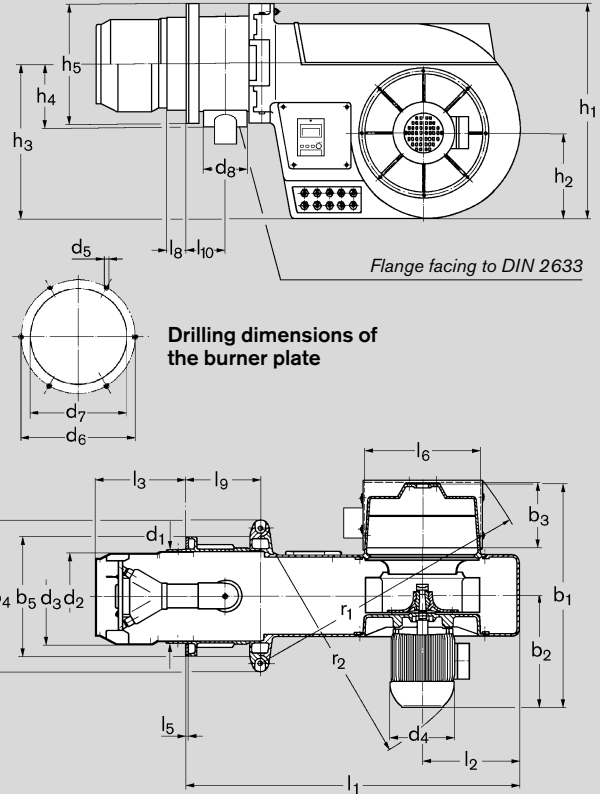
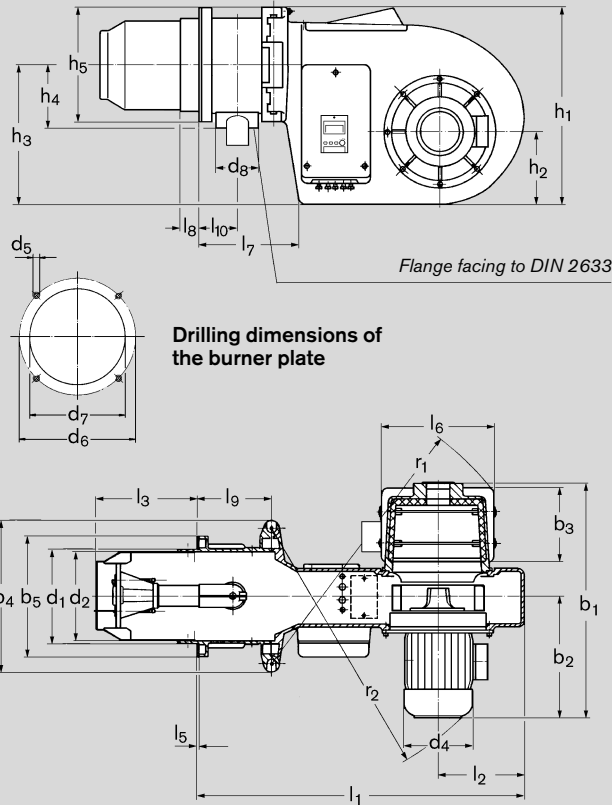

Size	Dimensions in mm														
	l ₁	l ₂	l ₃	l ₅	l ₆	l ₇	l ₈	l ₉	l ₁₀	b ₁	b ₂	b ₃	b ₄	b ₅	
30/2-A	1083	245	257	8	354	300	58	238	123	700	371	208	418	□ 330	
40/1-B	1128	270	257	8	414	320	58	238	123	755	401	242	462	□ 330	
40/2-A	1148	270	367	8	414	340	67	258	133	755	401	242	462	□ 370	
50/1-B	1195	315	367	8	422	363	67	258	133	820	440	277	550	□ 370	
50/2-A	1245	315	387	8	422	413	72	308	158	860	465	277	550	□ 430	
60/2-A	1478	405	432	8	508	440	89	348	178	980	487	280	670	□ 520	
70/1-B	1648	483	432	8	614	510	89	348	178	1125	557	340	760	□ 520	
70/2-A	1668	483	437	8	614	530	102	368	188	1170	602	340	760	□ 600	
	h ₁	h ₂	h ₃	h ₄	h ₅	d ₁	d ₂	d ₃	d ₄	d ₅	d ₆	d ₇	d ₈	r ₁	r ₂
30/2-A	572	207	407	207	□ 330	280	260	-	218	M12	360	285	DN50	840	890
40/1-B	607	211	422	207	□ 330	280	260	-	218	M12	360	285	DN50	895	970
40/2-A	607	211	422	227	□ 370	320	296	-	218	M12	400	325	DN65	895	970
50/1-B	730	263	513	227	□ 370	320	296	-	258	M12	400	325	DN65	1060	1000
50/2-A	730	263	513	257	□ 430	380	350	-	258	M16	480	390	DN80	1060	1025
60/2-A	930	360	670	302	□ 520	432	406	-	258	M16	470	435	DN100	1250	1140
70/1-B	1075	420	775	302	□ 520	432	406	-	310	M16	470	435	DN100	1440	1310
70/2-A	1075	420	775	315	□ 600	470	-	480	310	M16	550	500	DN100	1440	1310

All measurements are approximate. Weishaupt reserve the right to make alterations in light of future developments.

Dimensions LN version

-weishaupt-

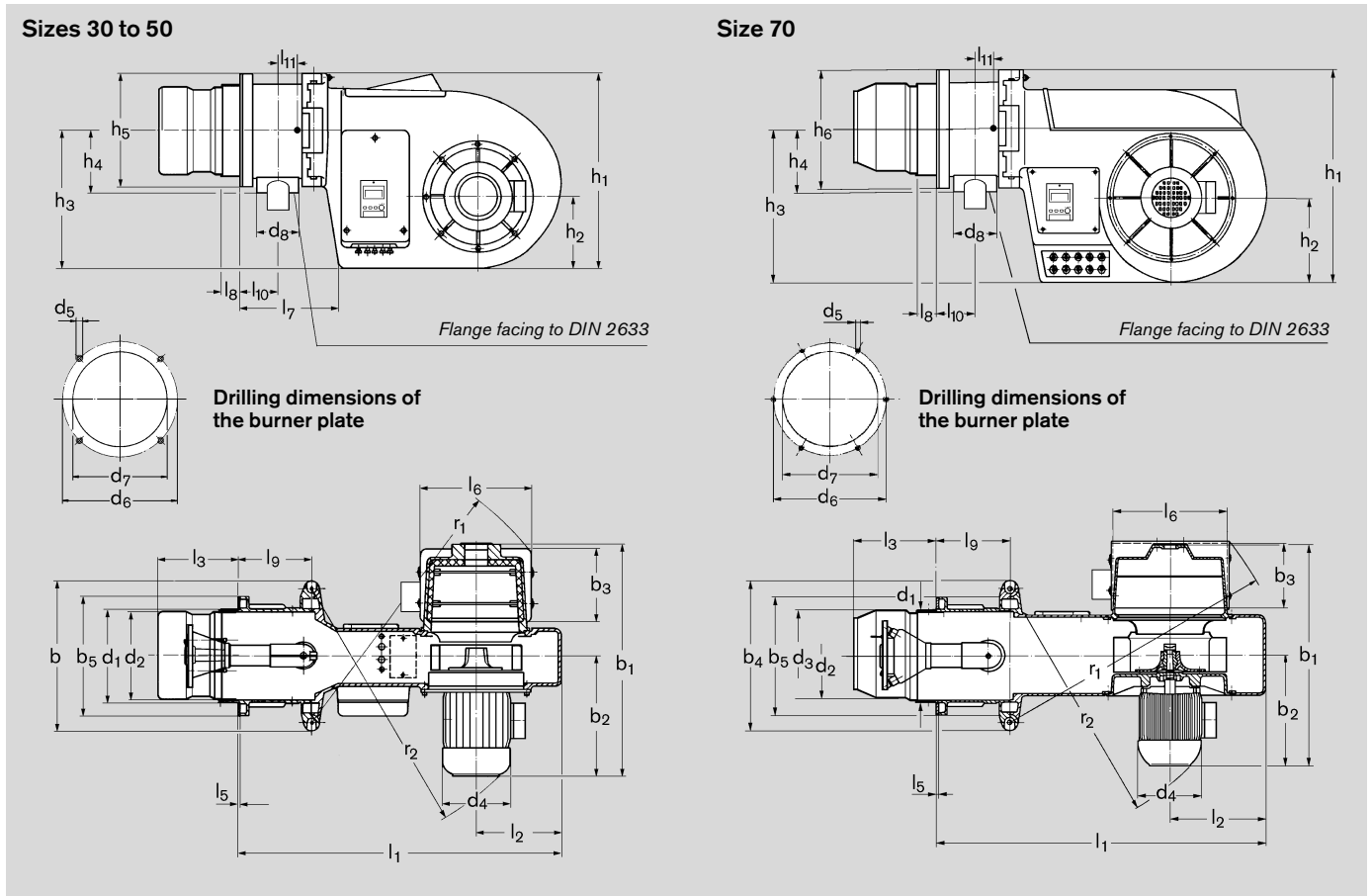

Size	Dimensions in mm														
	l ₁	l ₂	l ₃	l ₅	l ₆	l ₇	l ₈	l ₉	l ₁₀	l ₁₁	b ₁	b ₂	b ₃	b ₄	b ₅
30/2-A	1083	245	272	8	354	300	58	238	123	32	700	371	208	418	□ 330
40/1-B	1128	270	272	8	414	320	58	238	123	32	755	401	242	462	□ 330
40/2-A	1148	270	332	8	414	340	67	258	133	42	755	401	242	462	□ 370
50/1-B	1195	315	332	8	422	363	67	258	133	42	820	440	277	550	□ 370
50/2-A	1245	315	447	8	422	413	72	308	158	65	860	465	277	550	□ 430
70/1-B	1648	483	419	8	614	510	89	348	178	87	1125	602	340	760	□ 520
70/2-A	1668	483	447	8	614	530	102	368	188	87	1170	602	340	760	□ 600
	h ₁	h ₂	h ₃	h ₄	h ₅	d ₁	d ₂	d ₃	d ₄	d ₅	d ₆	d ₇	d ₈	r ₁	r ₂
30/2-A	572	207	407	207	□ 330	280	250	-	218	M12	360	285	DN50	840	890
40/1-B	607	211	422	207	□ 330	280	250	-	218	M12	360	285	DN50	895	970
40/2-A	607	211	422	227	□ 370	320	290	-	218	M12	400	325	DN65	895	970
50/1-B	730	263	513	227	□ 370	320	290	-	258	M12	400	325	DN65	1060	1000
50/2-A	730	263	513	257	□ 430	380	350	-	258	M16	480	390	DN80	1060	1025
70/1-B	1075	420	775	302	□ 520	432	406	-	310	M16	470	435	DN100	1440	1310
70/2-A	1075	420	775	315	□ 600	470	-	480	310	M16	550	500	DN100	1440	1310

All measurements are approximate. Weishaupt reserve the right to make alterations in light of future developments.

Product and customer service - the complete Weishaupt range

Max Weishaupt GmbH
D - 88475 Schwendi
Tel.: (07353) 830, Fax.: (07353) 83358
www.weishaupt.co.uk

Print No. 83017802, June 2003
Printed in Germany. All rights reserved.

Neachells Lane, Willenhall, WV13 3RG
Tel.: (01902) 609841, Fax: (01902) 633343

63 Carlton Place, Glasgow, G5 9TW
Tel: (0141) 420 2030, Fax: (0141) 420 2088

— weishaupt —



Regular maintenance reduces heating costs and environmental pollution. Only a properly adjusted burner can save energy and be environmentally friendly. Behind each Weishaupt burner stands the whole Weishaupt customer service organisation. The outstanding efforts made in maintenance and service justify the enormous trust placed in Weishaupt's burners, for at Weishaupt product and customer service belong together.

Weishaupt customer service is there for you all year round. Whenever you need help, be it the supply of spare parts, technical advice or a site visit. We are there when you need us.